

# San Antonio 10EJV

PreMP BUILD 0307

www.kythuatvithinh.com

DATE	CHANGE NO.	REV

DRAWER	EE	DATE	POWER	DATE	<b>INVENTEC</b>	
DESIGN						
CHECK						
RESPONSIBLE						
TITLE					<b>SA10EJV</b>	
SIZE =	3	VER :				
FILE NAME :	XXXX-XXXXXX-XX				SIZE	A3
P/N	XXXXXXXXXXXX				CODE	CS
					DOC. NUMBER	
					REV	A02
					SHEET	1 OF 51

## TABLE OF CONTENTS

PAGE	PAGE
1.COVER PAGE	32.RTC
2.INDEX	33.CARDBUS CONTROLLER
3.BLOCK DIAGRAM	34.PCMCIA & EXPRESS CARD
4.POWER SEQUENCE BLOCK	35.5 IN 1 MEMORY CARD
5-11.SYSTEM POWER	36.1394 CONTROLLER
12.CLOCK GENERATOR	37.MINIPCI CONN
13.CPU(1/4)	38.LAN CONTROLLER
14.CPU(2/4)	39.RJ45 & TRANSFORMER
15.CPU(3/4)	40.HDD CONN
16.CPU(4/4)	41.ODD CONN
17.FAN&THERMAL CONTROLLER	42.USB CONN
18.N/B(1/5)	43.SUPER I/O
19.N/B(2/5)	44.K/B & D/B CONN
20.N/B(3/5)	45.AC97 CODEC
21.N/B(4/5)	46.AUDIO AMP
22.N/B(5/5)	47.MDC
23.DDR2 DIMM0	48.SWITCH & LED (MB)
24.DDR2 DIMM1	49.SWITCH & LED (DB)
25.DDR2 DAMPING	50.USB & SVIDEO BOARD
26.CRT	51.TP BOARD
27.LCM	
28.S-VIDEO	
29.S/B(1/5)	
30.S/B(2/5)	
31.S/B(3/5)	

**INVENTEC**

TITLE SA10EJV

SIZE <b>A3</b>	CODE <b>CS</b>	DOC. NUMBER <b>1310A2076701</b>	REV <b>A02</b>
-------------------	-------------------	------------------------------------	-------------------

CHANGE by *Kobby Wen* 21-Feb-2006

SHEET 2 OF 51

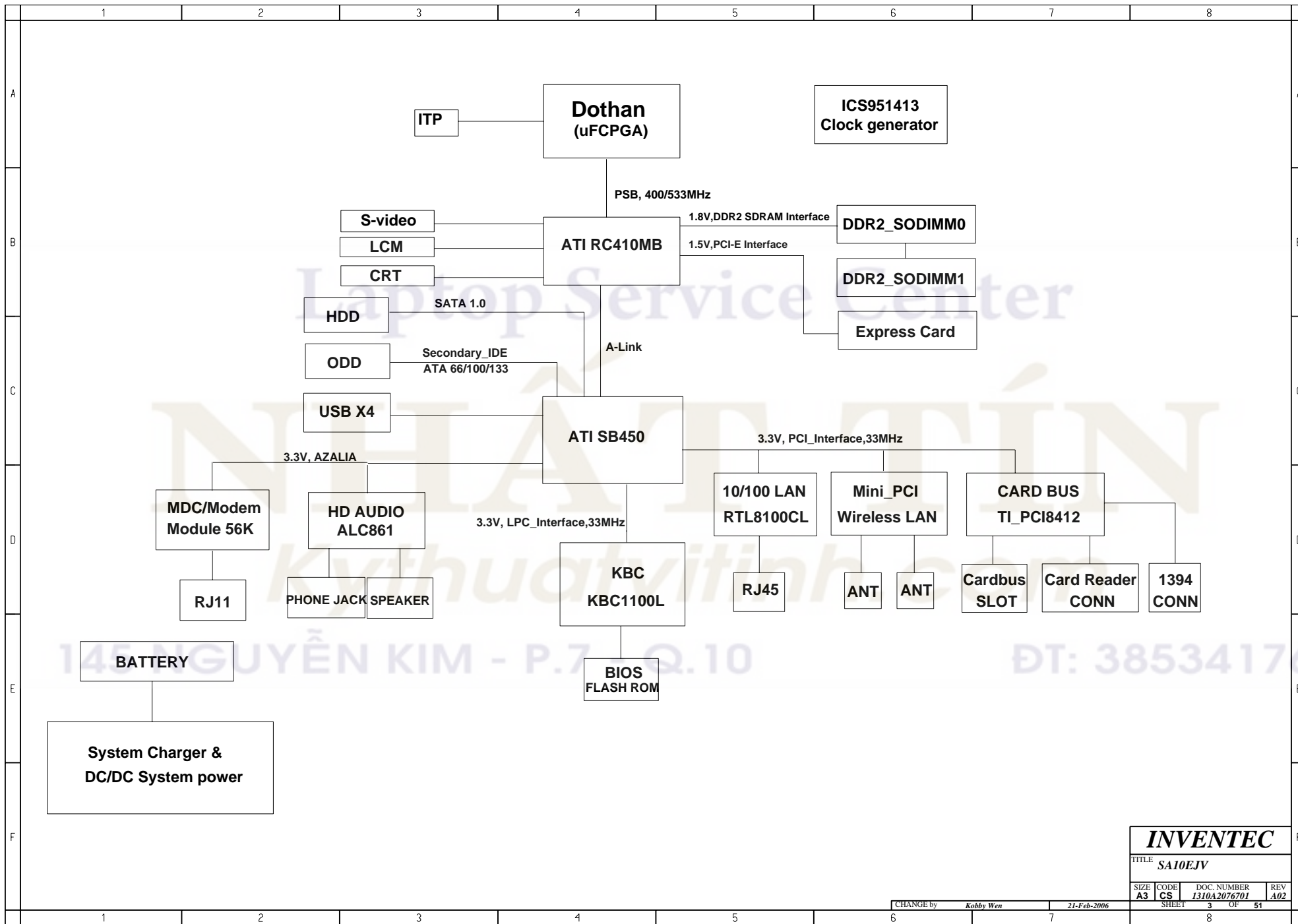

**INVENTEC**

TITLE **SA10EJV**

SIZE <b>A3</b>	CODE <b>CS</b>	DOC. NUMBER <b>1310A2076701</b>	REV <b>A02</b>
-------------------	-------------------	------------------------------------	-------------------

CHANGE by *Kobby Wen* 21-Feb-2006

SHEET 3 OF 51

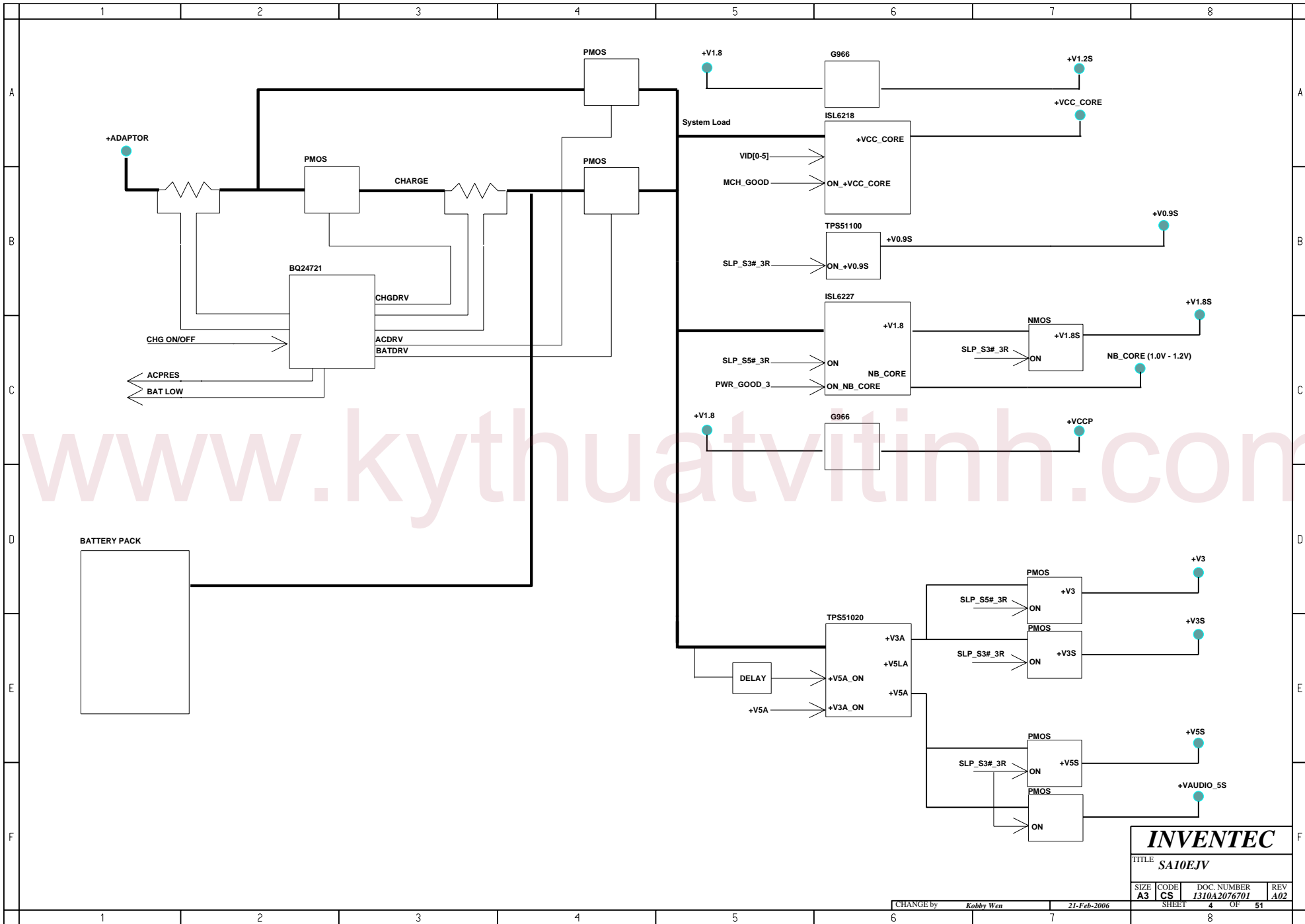

www.kythuatvithinh.com

<b>INVENTEC</b>			
TITLE <b>SA10EJV</b>			
SIZE <b>A3</b>	CODE <b>CS</b>	DOC. NUMBER <b>1310A2076701</b>	REV <b>A02</b>
CHANGE by <i>Kobby Wen</i>		21-Feb-2006	
SHEET 4		OF 51	

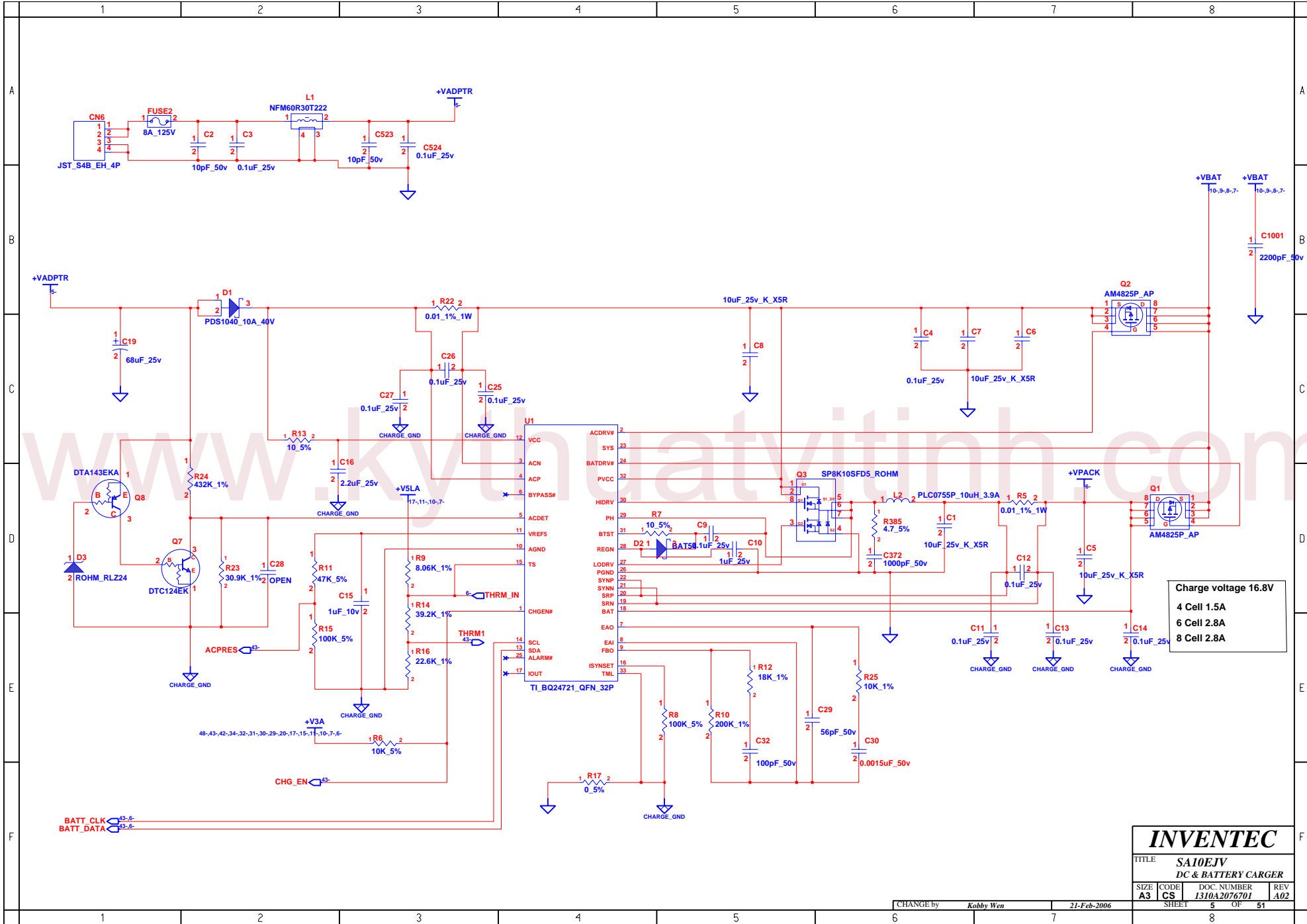

Charge voltage 16.8V  
 4 Cell 1.5A  
 6 Cell 2.8A  
 8 Cell 2.8A

<b>INVENTEC</b>			
TITLE <b>SA10EJV</b>			
DC & BATTERY CHARGER			
SIZE <b>A3</b>	CODE <b>CS</b>	DOC. NUMBER <b>1310A2076701</b>	REV <b>A02</b>
CHANGE by <i>Kobby Wen</i>		21-Feb-2006	
SHEET <b>5</b>		OF <b>51</b>	

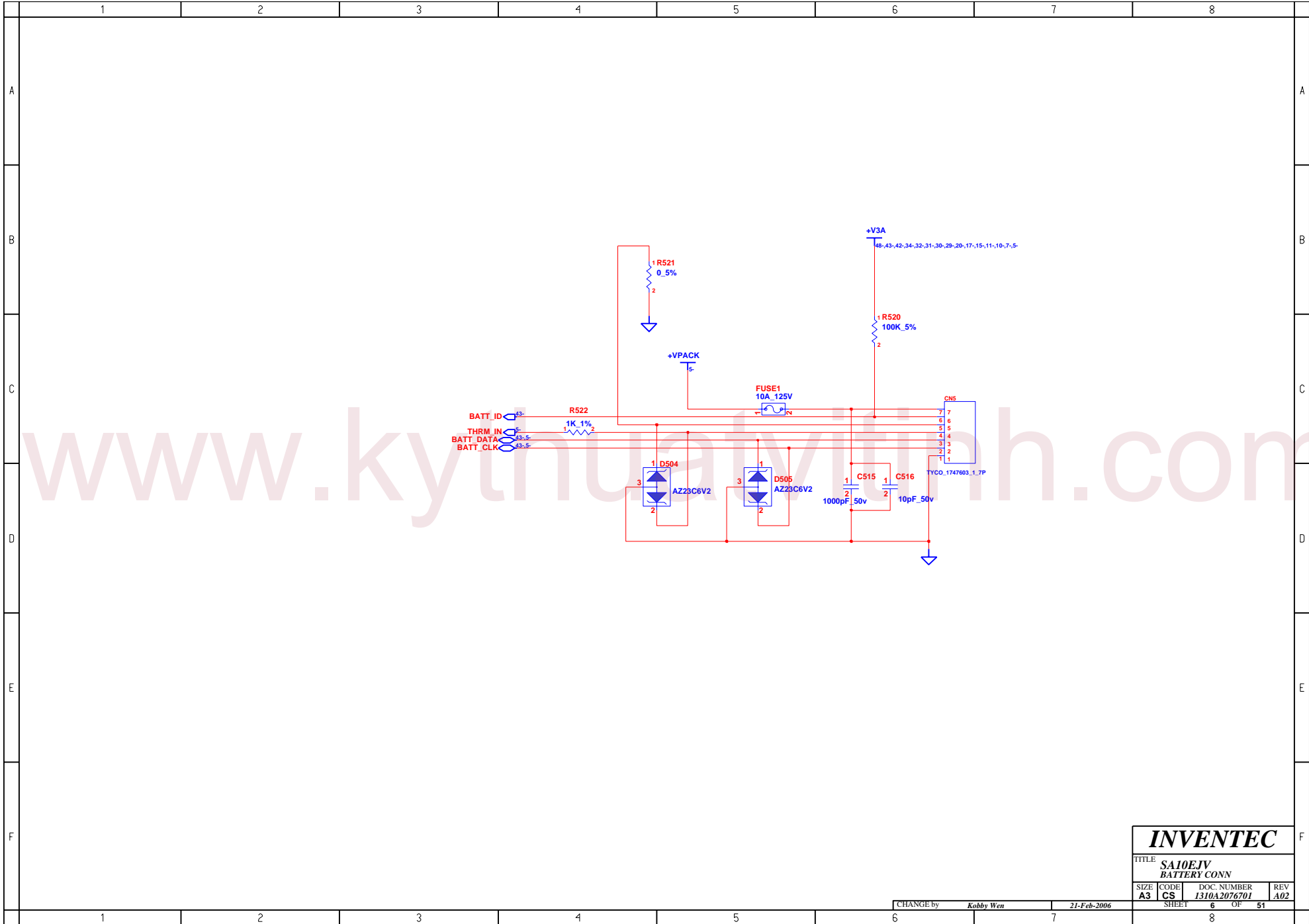

**INVENTEC**

TITLE  
SA10EJV  
BATTERY CONN

SIZE A3	CODE CS	DOC. NUMBER 1310A2076701	REV A02
------------	------------	-----------------------------	------------

CHANGE by *Kobby Wen* 21-Feb-2006

SHEET 6 OF 51

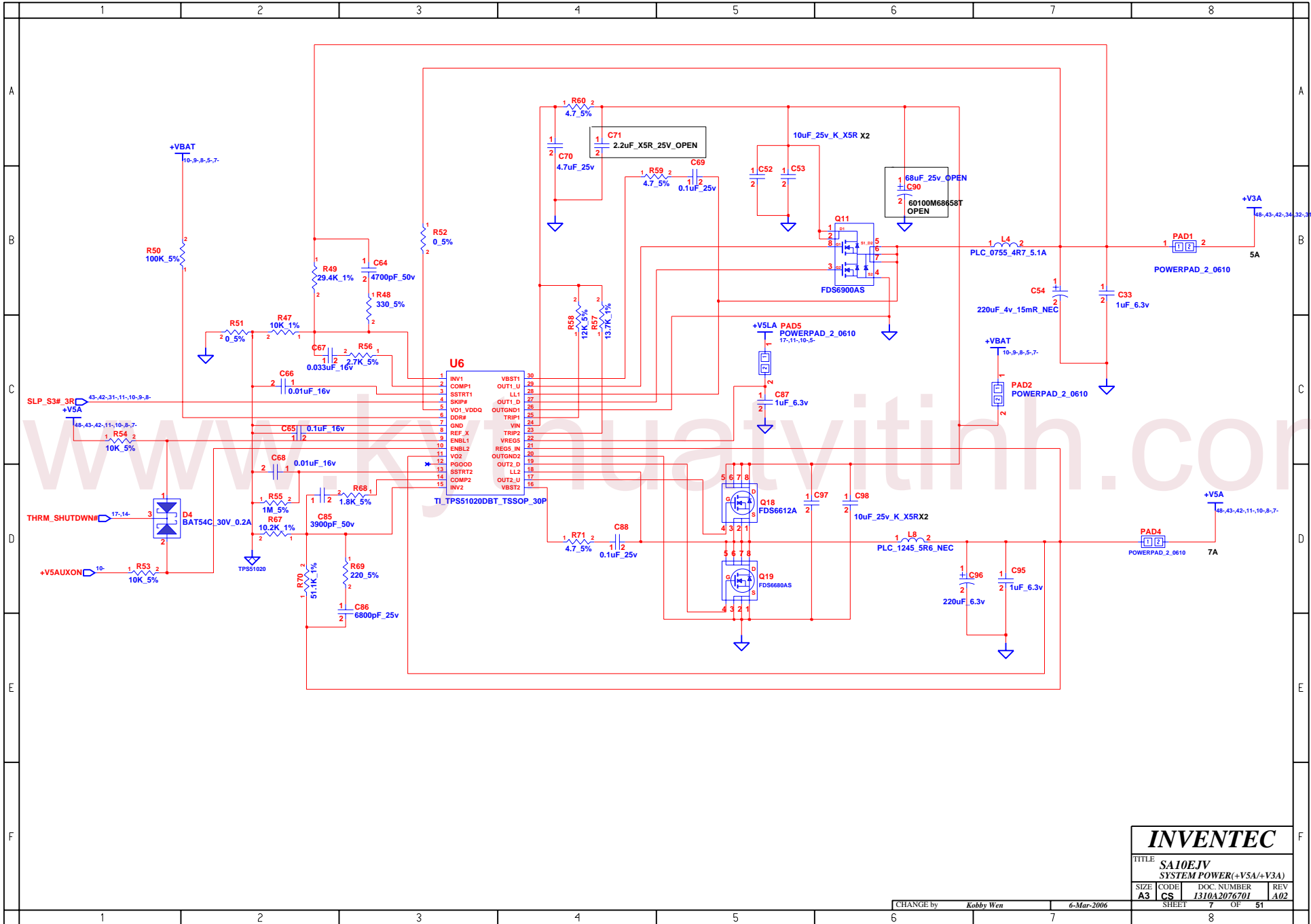

**INVENTEC**

TITLE SA10EJV			
SYSTEM POWER(+V5A/+V3A)			
SIZE A3	CODE CS	DOC NUMBER 1310A2076701	REV A02

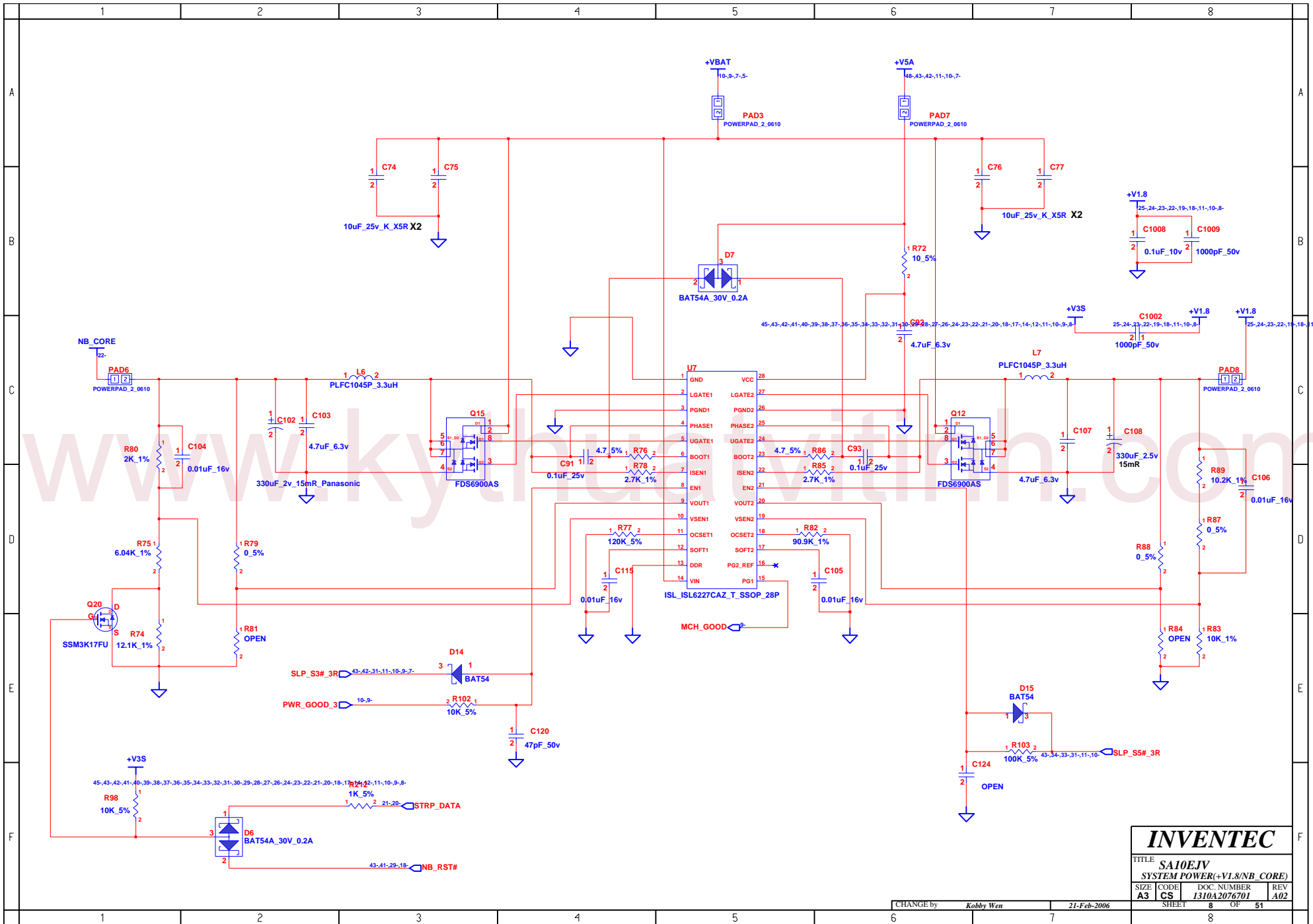

<b>INVENTEC</b>			
TITLE SAI0EJV			
SYSTEM POWER(+V1.8/NB_CORE)			
SIZE A3	CODE CS	DOC. NUMBER I310A2076701	REV A02
CHANGE by Kobby Wen		21-Feb-2006	
SHEET 8		OF 51	



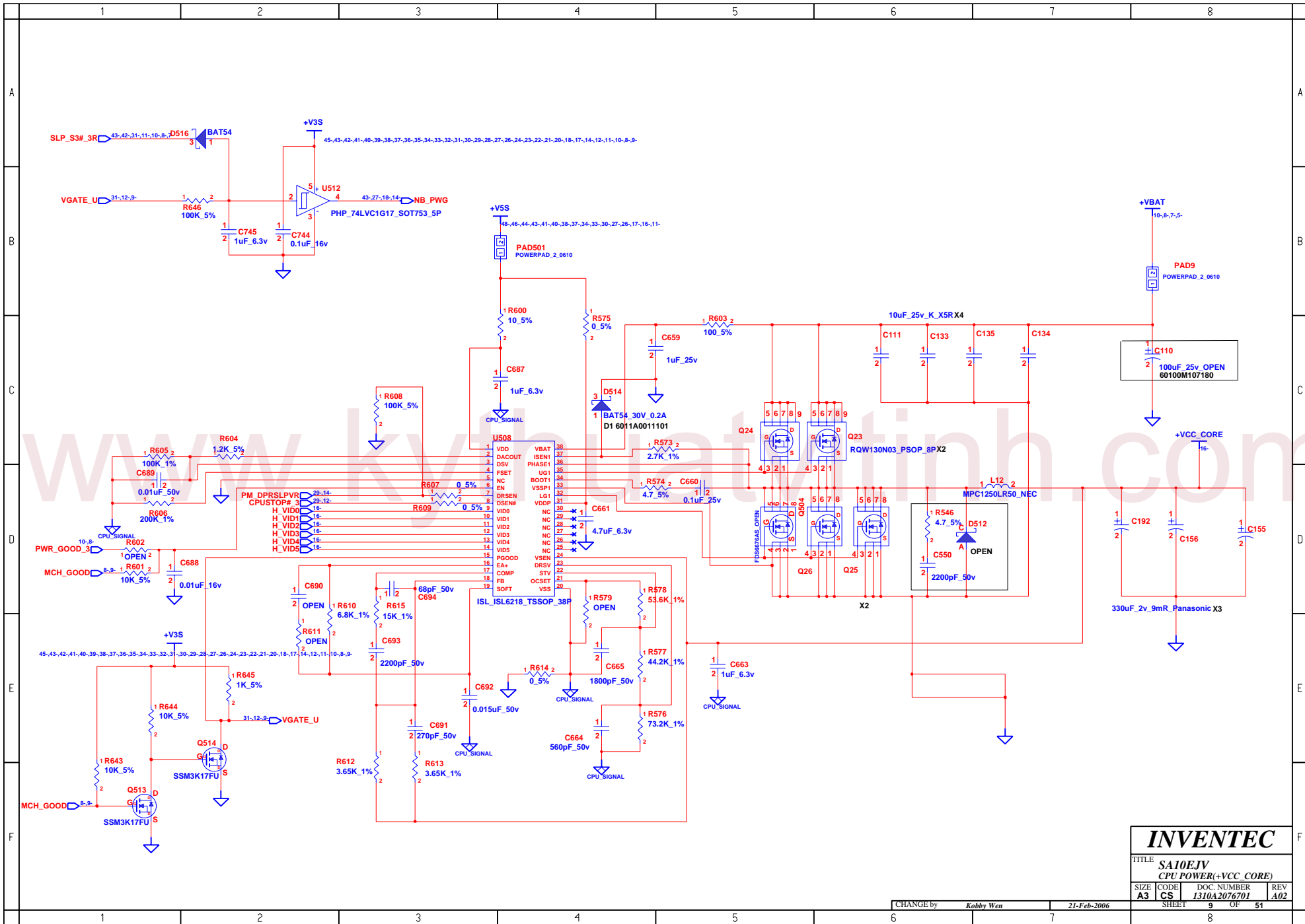

<b>INVENTEC</b>			
TITLE SA10EJV CPU POWER(+VCC_CORE)			
SIZE A3	CODE CS	DOC. NUMBER I310A2076701	REV A02
CHANGE by Kobby Wen		21-Feb-2006	
SHEET 9		OF 51	

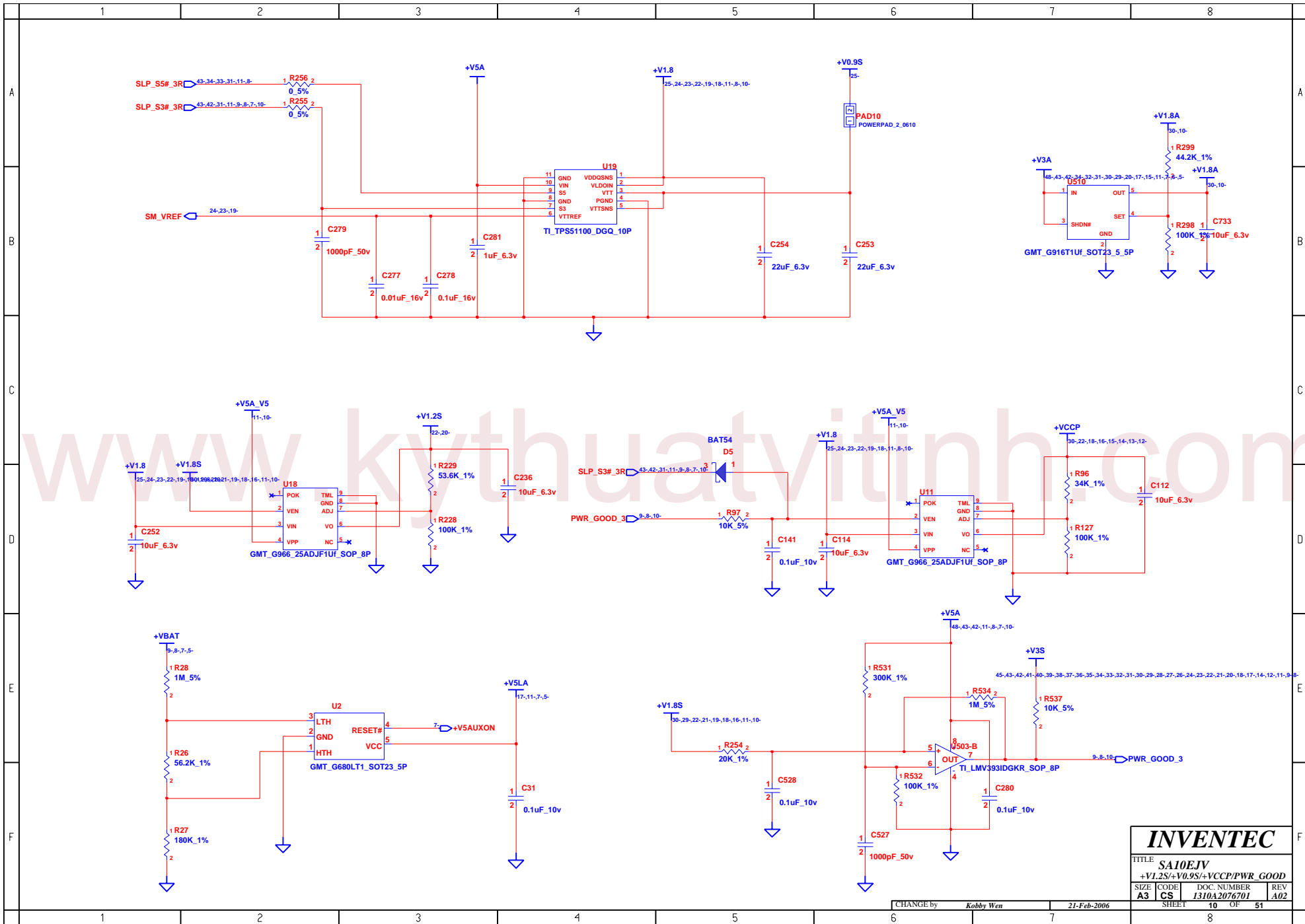

<b>INVENTEC</b>			
TITLE <b>SAI0EJV</b>			
+V1.2S/+V0.9S/+VCCCP/PWR_GOOD			
SIZE <b>A3</b>	CODE <b>CS</b>	DOC. NUMBER <b>1310A2076701</b>	REV <b>A02</b>
CHANGE by <i>Kobby Wen</i>		21-Feb-2006	
SHEET <b>10</b>		OF <b>51</b>	

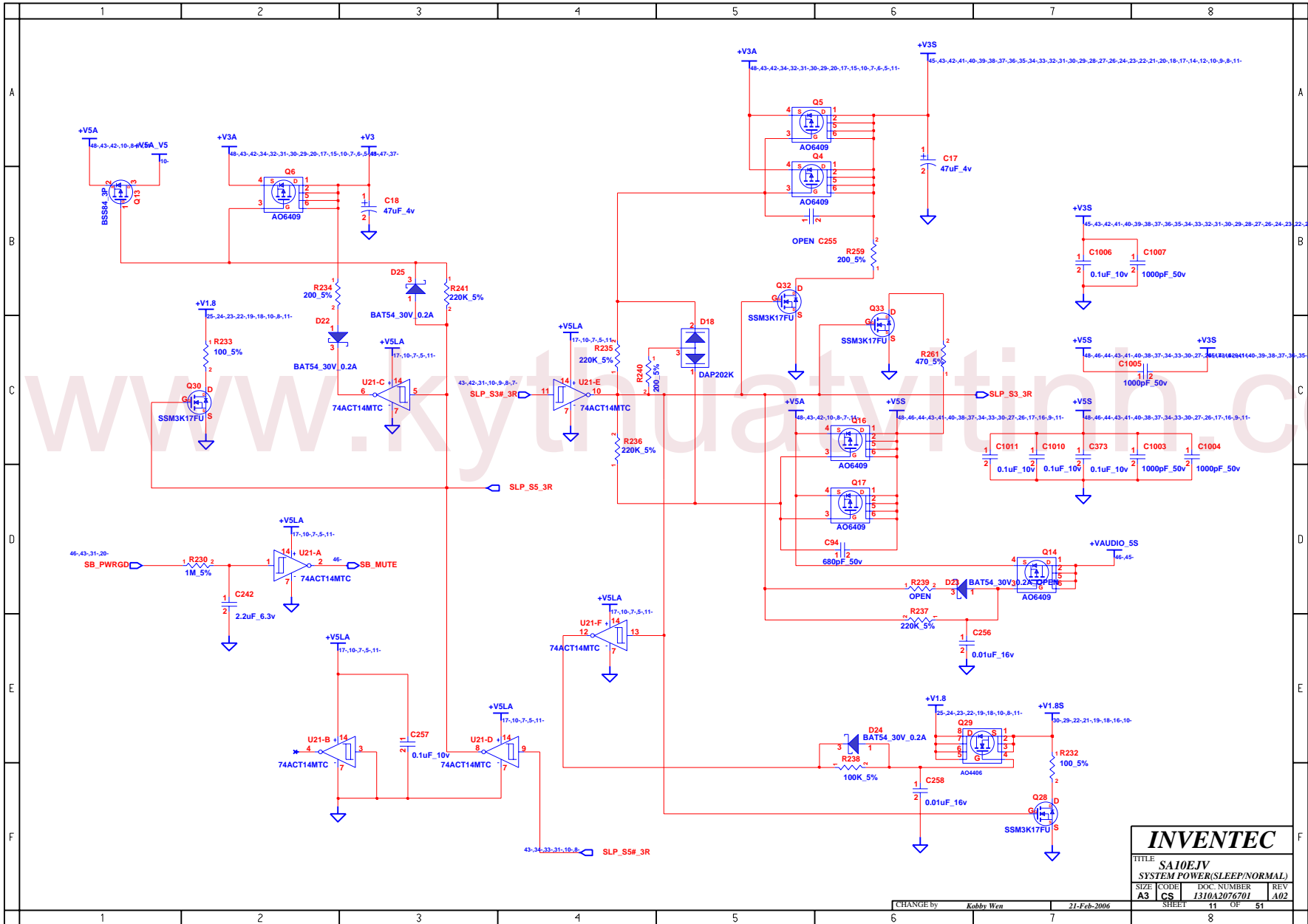

**INVENTEC**

TITLE SA10EJV  
SYSTEM POWER(SLEEP/NORMAL)

SIZE	CODE	DOC. NUMBER	REV
A3	CS	I310A2076701	A02

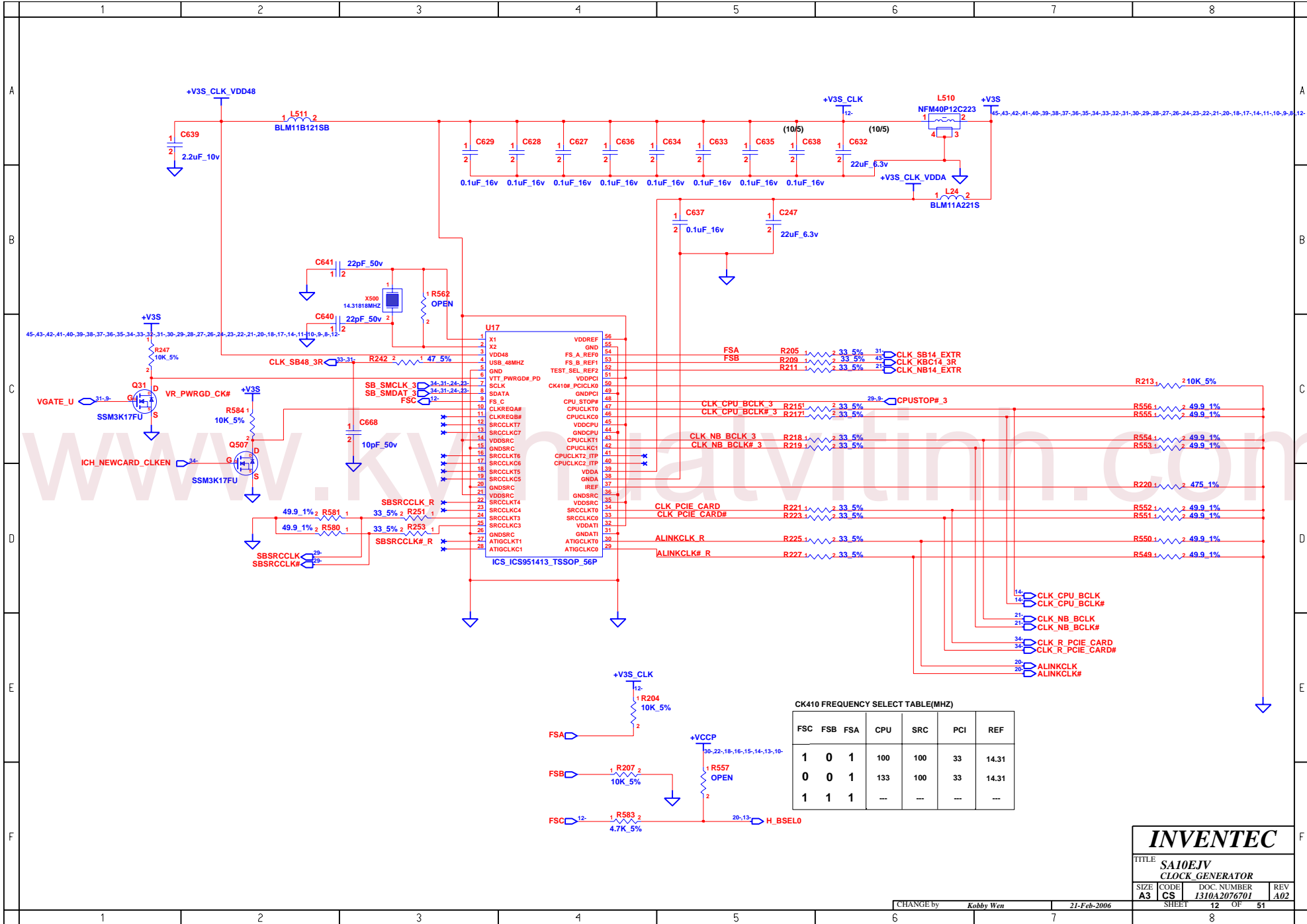

CK410 FREQUENCY SELECT TABLE(MHZ)

FSC	FSB	FSA	CPU	SRC	PCI	REF
1	0	1	100	100	33	14.31
0	0	1	133	100	33	14.31
1	1	1	---	---	---	---

**INVENTEC**

TITLE  
SA10EJV  
CLOCK GENERATOR

SIZE	CODE	DOC NUMBER	REV
A3	CS	1310A2076701	A02

CHANGE by Kobby Wen 21-Feb-2006

SHEET 12 OF 51

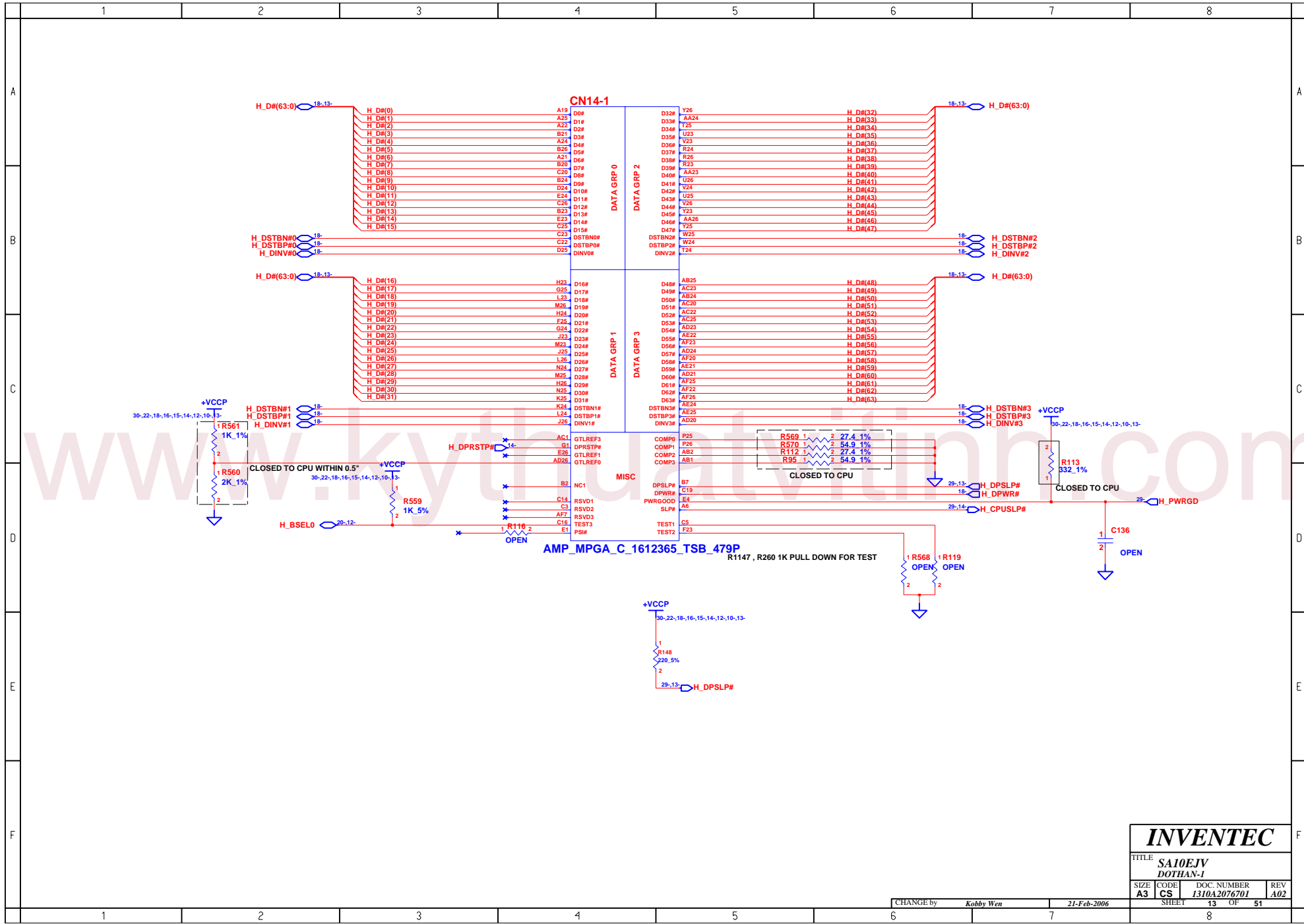

<b>INVENTEC</b>			
TITLE SA10EJV DOTHAN-1			
SIZE A3	CODE CS	DOC. NUMBER 1310A2076701	REV A02
CHANGE by Kobby Wen		21-Feb-2006	
SHEET 13		OF 51	

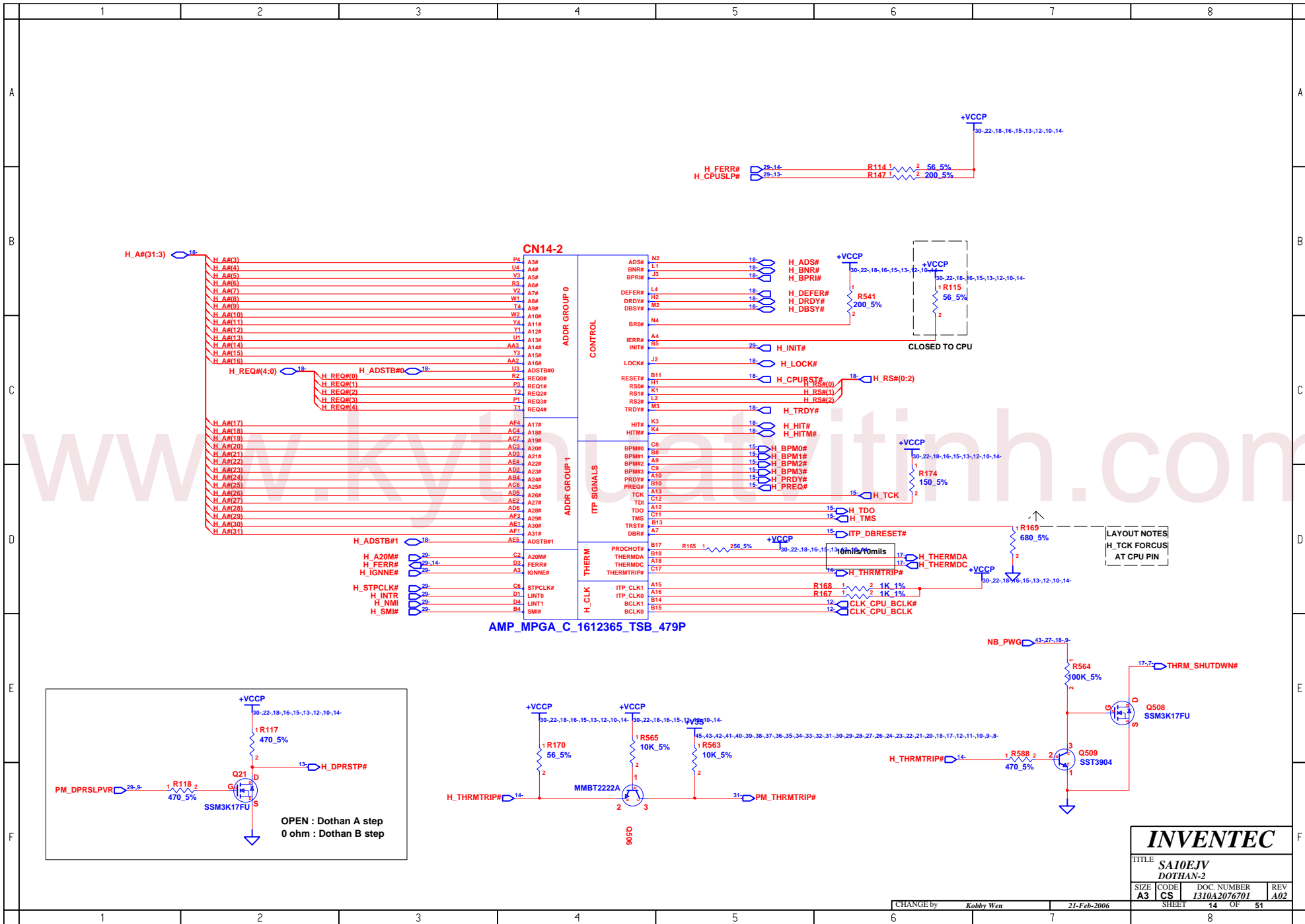

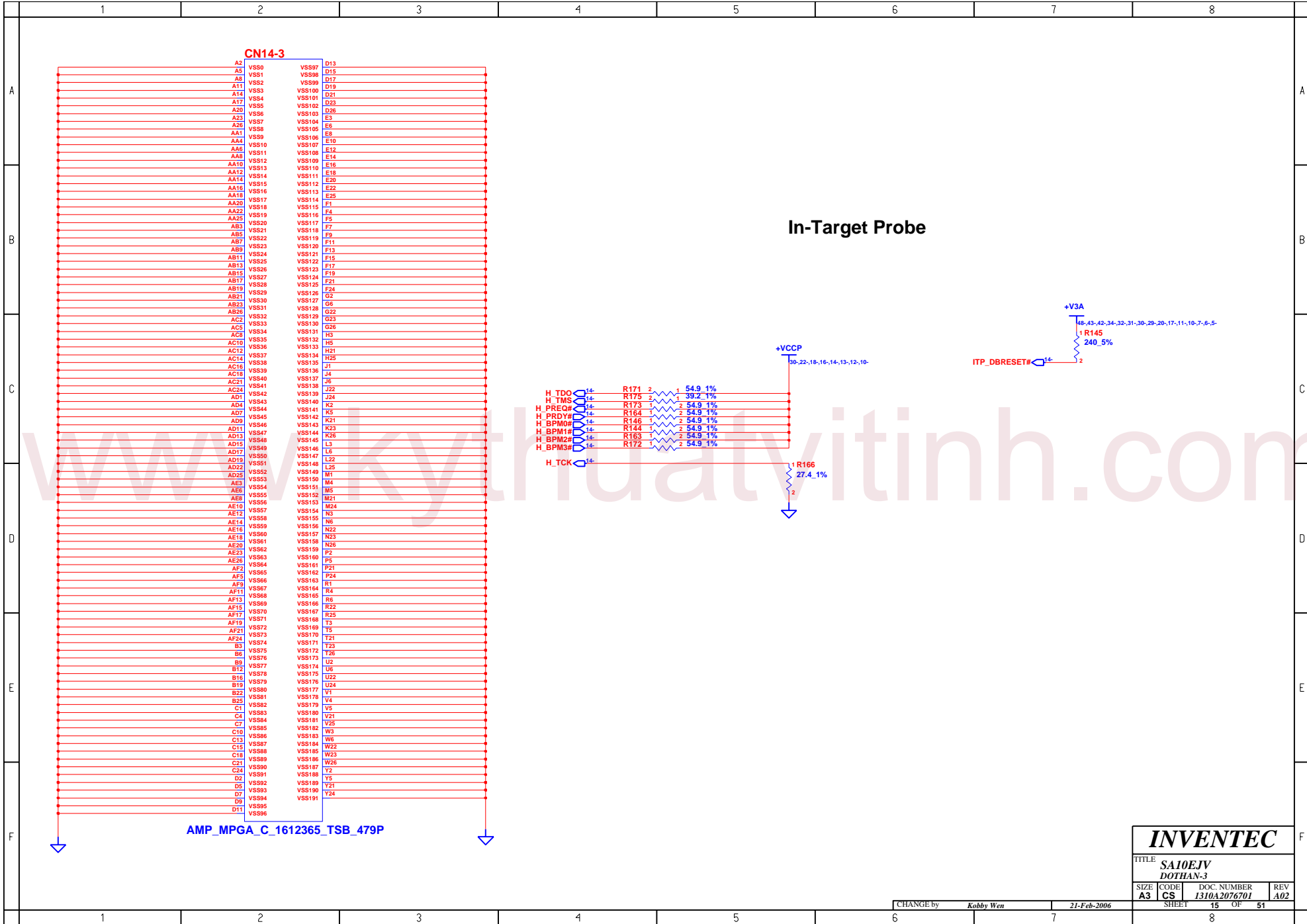

<b>INVENTEC</b>			
TITLE <b>SA10EJV</b> <b>DOHAN-3</b>			
SIZE <b>A3</b>	CODE <b>CS</b>	DOC. NUMBER <b>I310A2076701</b>	REV <b>A02</b>
CHANGE by <i>Kobby Wen</i>		21-Feb-2006	
SHEET		15 OF 51	

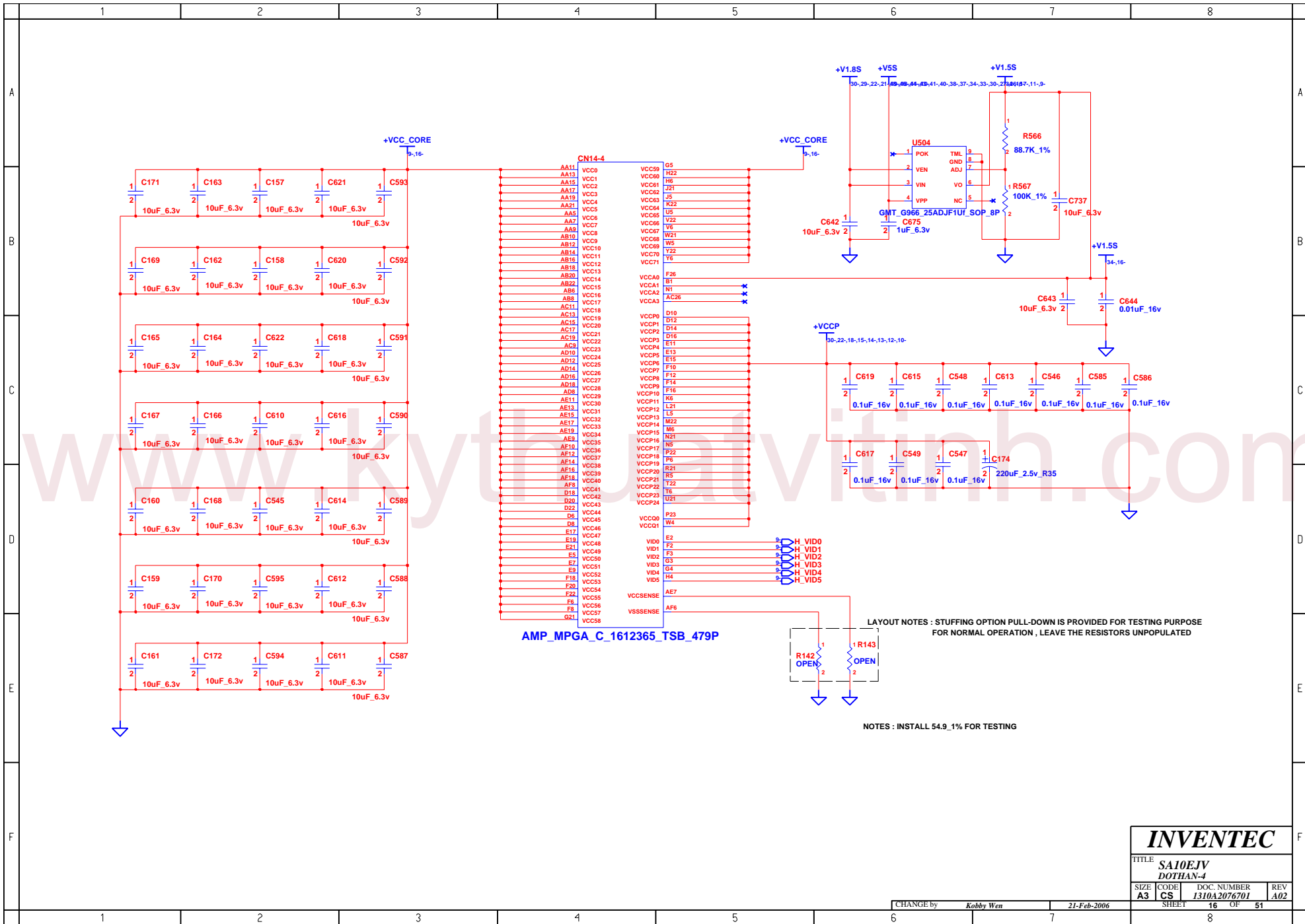

LAYOUT NOTES : STUFFING OPTION PULL-DOWN IS PROVIDED FOR TESTING PURPOSE FOR NORMAL OPERATION , LEAVE THE RESISTORS UNPOPULATED

NOTES : INSTALL 54.9\_1% FOR TESTING

<b>INVENTEC</b>			
TITLE SA10EJV DOZHAN-4			
SIZE A3	CODE CS	DOC. NUMBER 1310A2076701	REV A02
CHANGE by Kobby Wen		21-Feb-2006	
SHEET 16		OF 51	



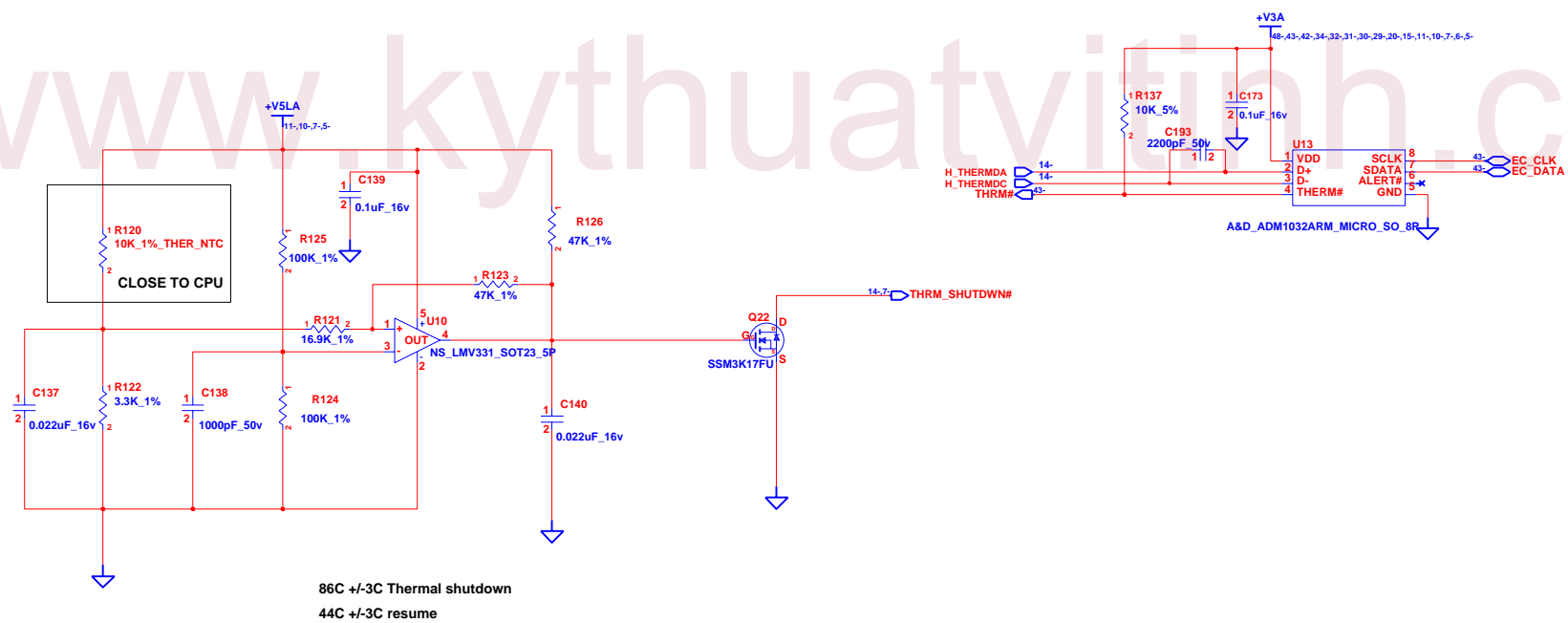
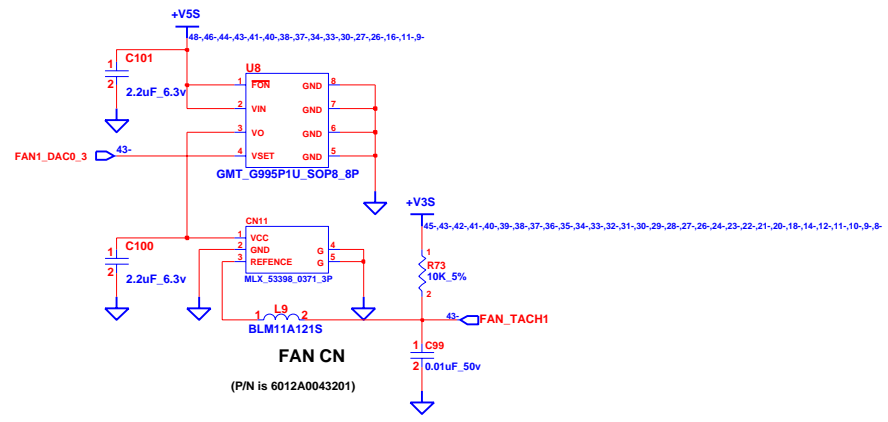

<b>INVENTEC</b>			
TITLE <b>SA10EJV</b> <b>THERMAL &amp; FAN CONTROLLER</b>			
SIZE <b>A3</b>	CODE <b>CS</b>	DOC. NUMBER <b>1310A2076701</b>	REV <b>A02</b>
CHANGE by <i>Kobby Wen</i>		SHEET <b>17</b>	OF <b>51</b>

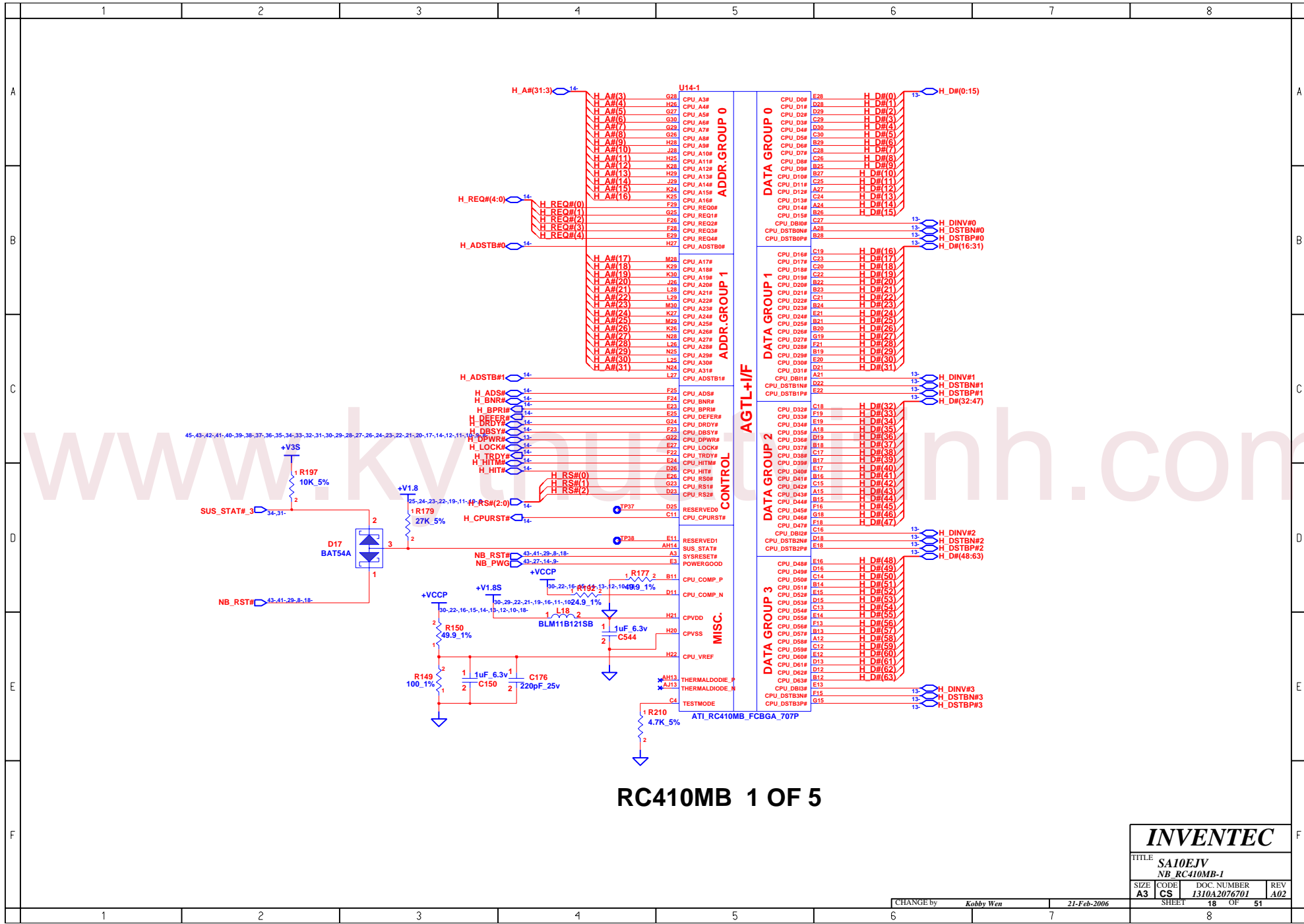

# RC410MB 1 OF 5

**INVENTEC**

TITLE			
SA10EJV			
NB_RC410MB-1			
SIZE	CODE	DOC. NUMBER	REV
A3	CS	1310A2076701	A02

CHANGE by	Kobby Wen	21-Feb-2006	SHEET	18	OF	51
-----------	-----------	-------------	-------	----	----	----

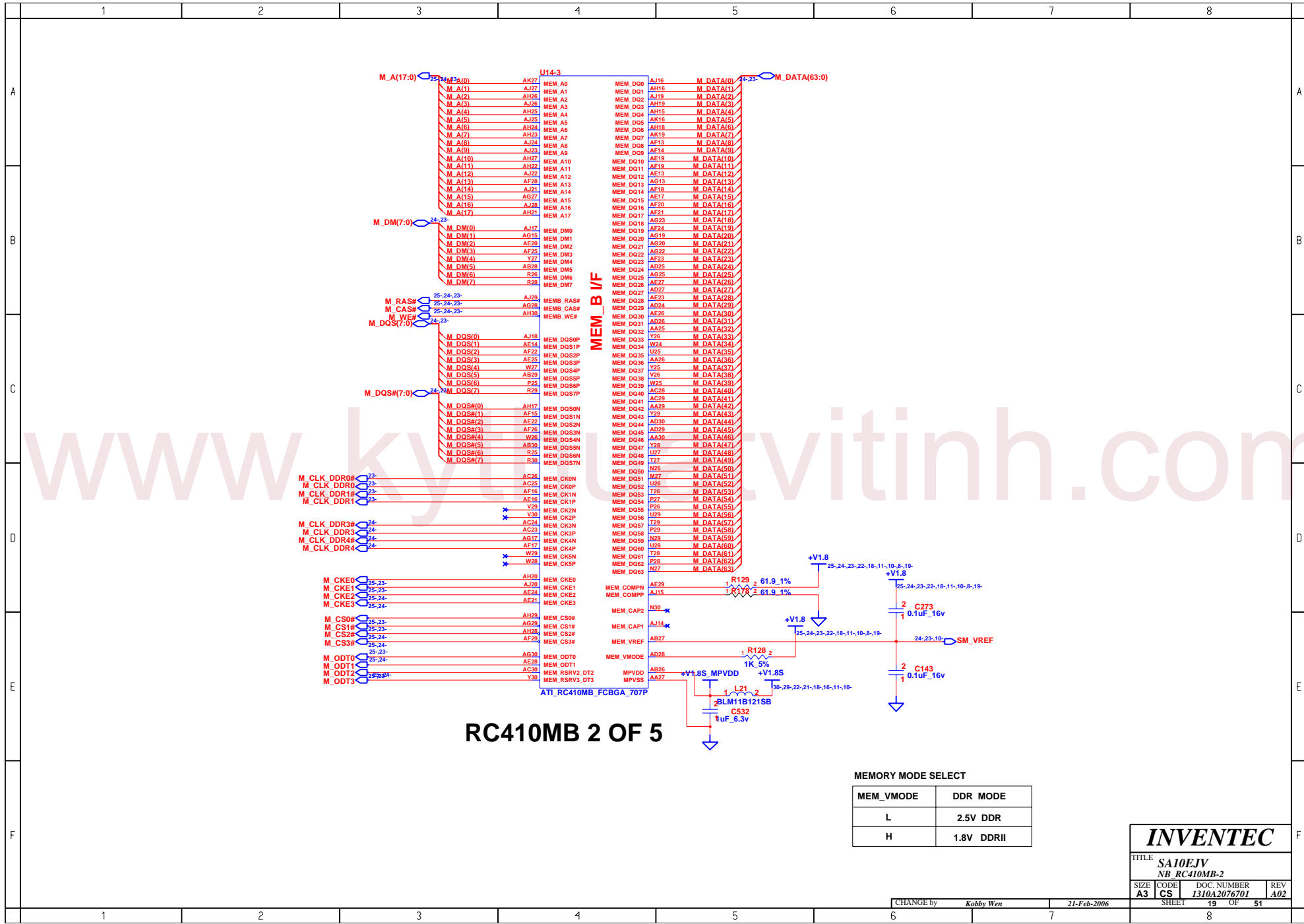

### RC410MB 2 OF 5

MEMORY MODE SELECT

MEM_VMODE	DDR MODE
L	2.5V DDR
H	1.8V DDRII

**INVENTEC**

TITLE: SA10EJV  
NB RC410MB-2

SIZE	CODE	DOC. NUMBER	REV
A3	CS	1310A2076701	A02

CHANGE by: Kobby Wen 21-Feb-2006 SHEET 19 OF 51

BMREQ#	DACHSYNC	DACVSYNC	FSB
0	0	1	133M 7X0
0	0	0	100M 7X5

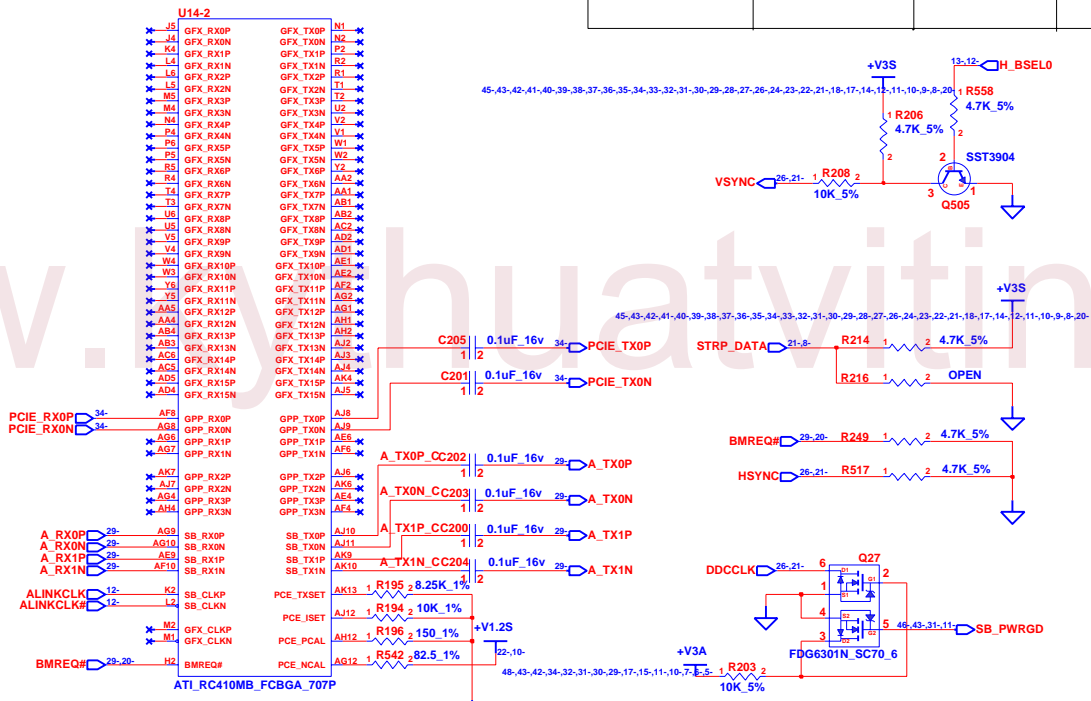

**RC410MB 3 OF 5**

0: MOBILE CPU  
1: DESKTOP CPU

<b>INVENTEC</b>			
TITLE SAI0EJV NB RC410MB-3			
SIZE A3	CODE CS	DOC. NUMBER 1310A2076701	REV A02
CHANGE by Kobby Wen		21-Feb-2006	
SHEET 20		OF 51	

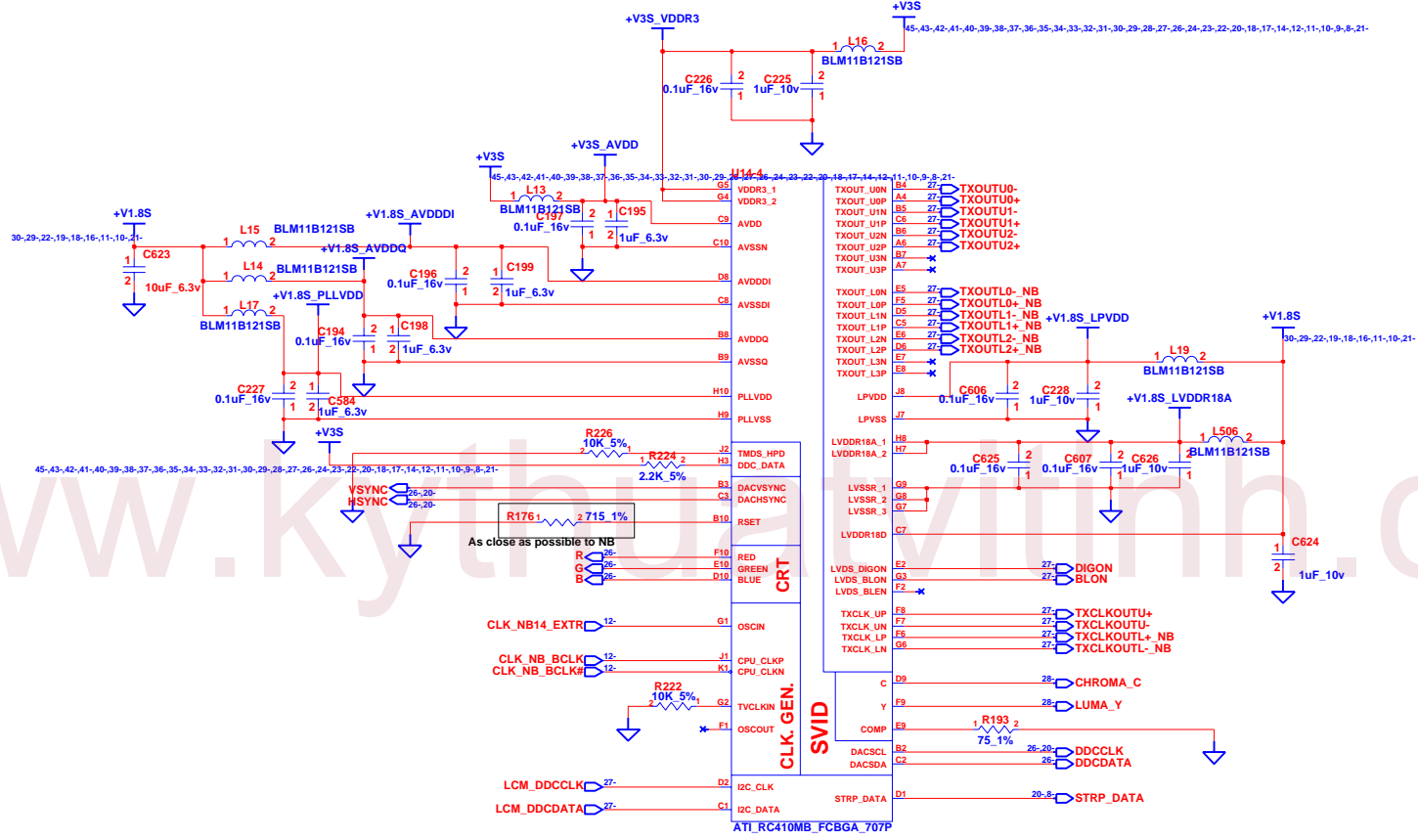

**RC410MB 4 OF 5**

<b>INVENTEC</b>			
TITLE SAI0EJV			
NB_RC410MB-4			
SIZE A3	CODE CS	DOC NUMBER 1310A2076701	REV A02
CHANGE by Kobby Wen		21-Feb-2006	
SHEET 21		OF 51	

www.kyocera.com

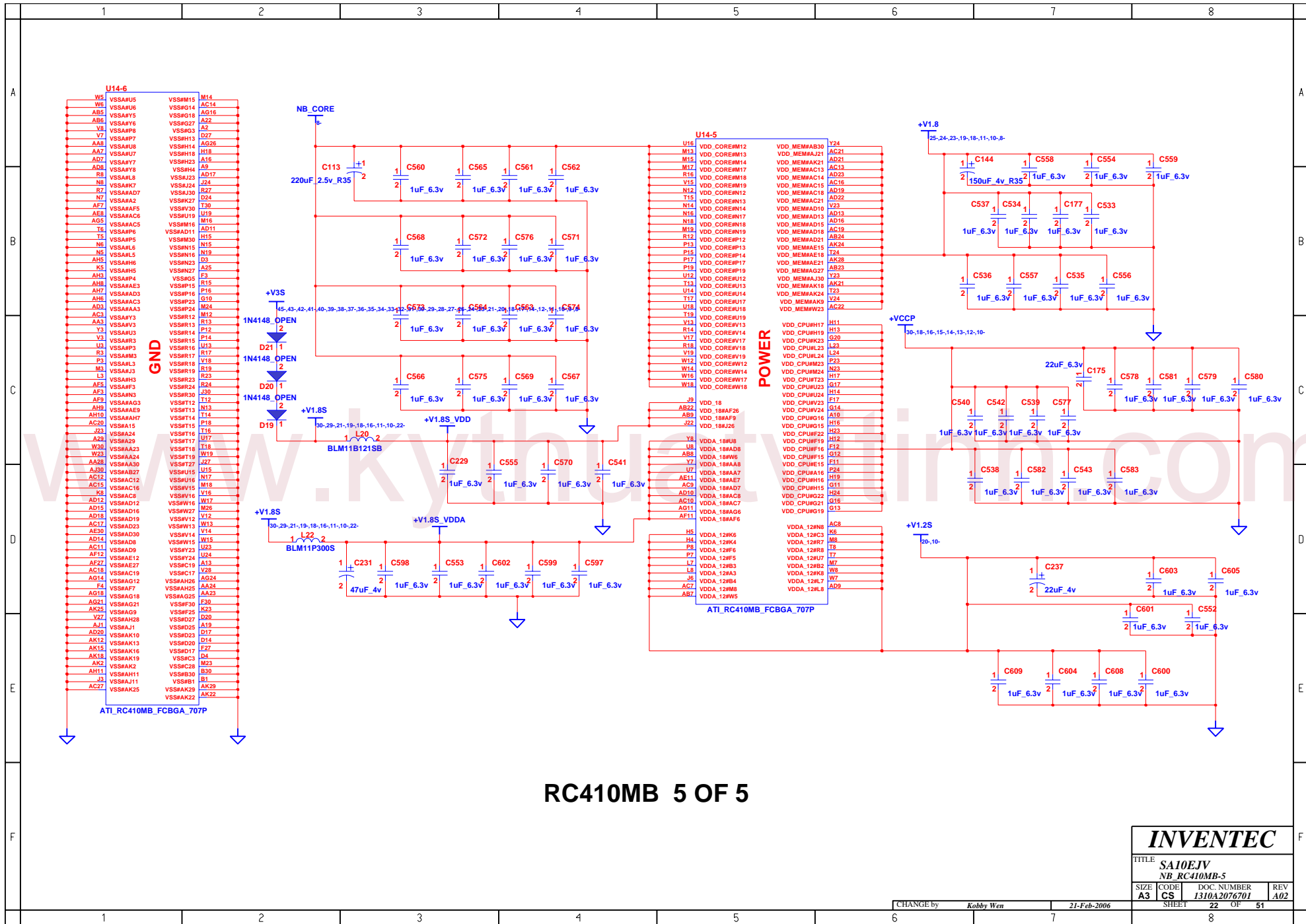

**RC410MB 5 OF 5**

<b>INVENTEC</b>			
TITLE SA10EJV			
NB_RC410MB-5			
SIZE A3	CODE CS	DOC. NUMBER 1310A2076701	REV A02
CHANGE by Kobby Wen		21-Feb-2006	
SHEET 22		OF 51	

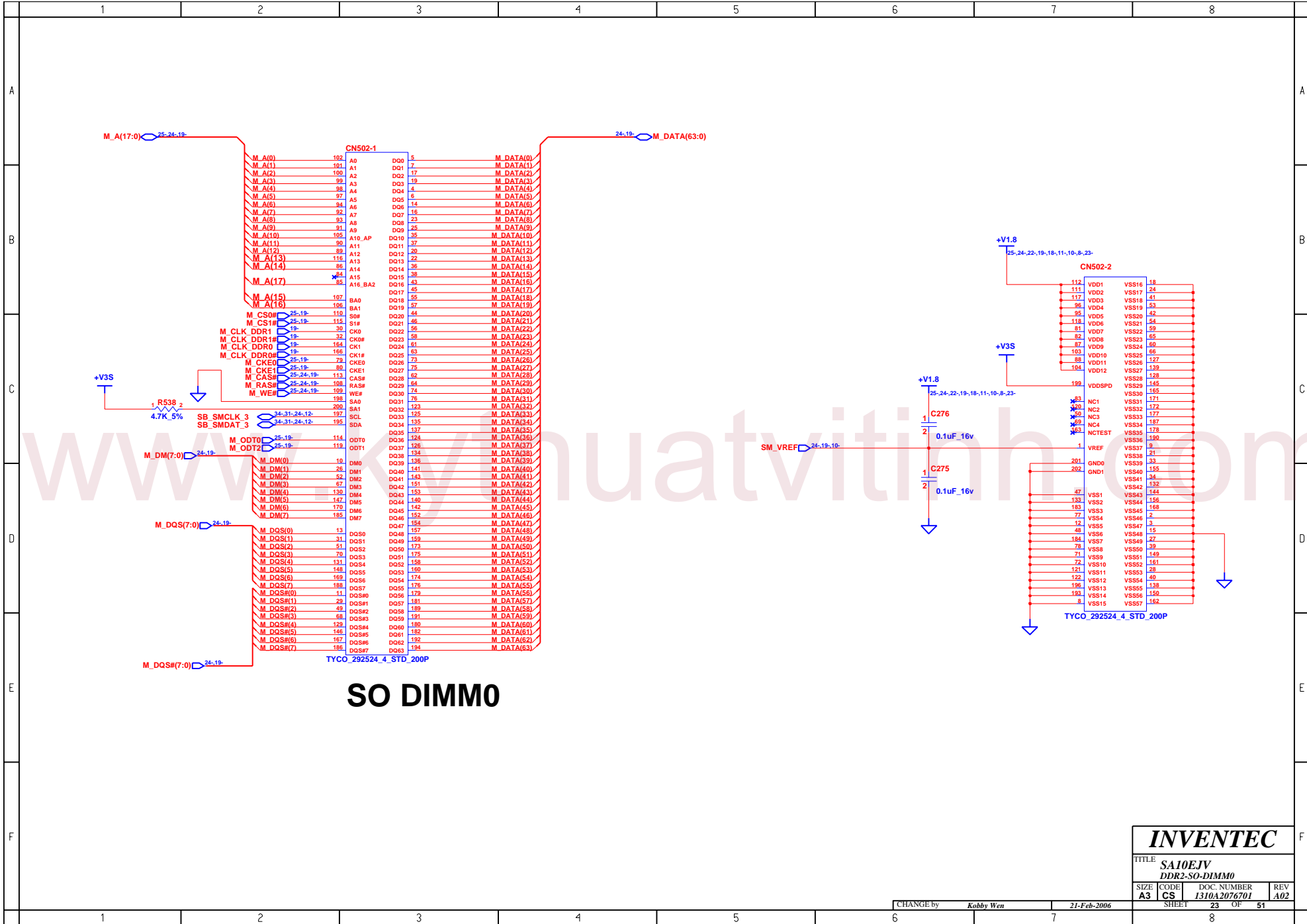

# SO DIMM0

<b>INVENTEC</b>			
TITLE <b>SA10EJV</b>			
<b>DDR2-SO-DIMM0</b>			
SIZE <b>A3</b>	CODE <b>CS</b>	DOC. NUMBER <b>1310A2076701</b>	REV <b>A02</b>
CHANGE by <i>Kobby Wen</i>		21-Feb-2006	
SHEET 23		OF 51	

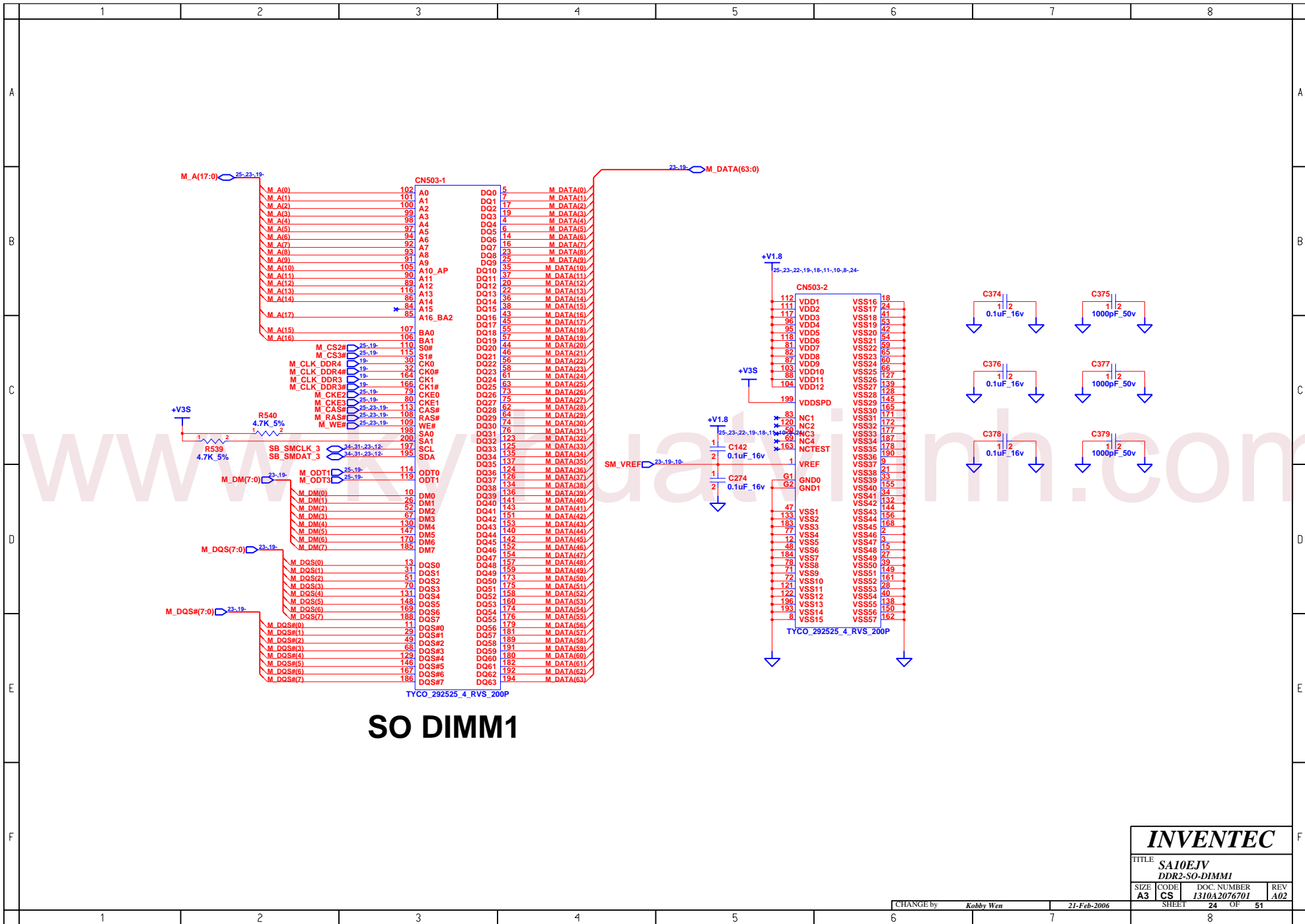

# SO DIMM1

## INVENTEC

TITLE			
SA10EJV			
DDR2-SO-DIMM1			
SIZE	CODE	DOC. NUMBER	REV
A3	CS	1310A2076701	A02

CHANGE by	Kobby Wen	21-Feb-2006	SHEET	24	OF	51
-----------	-----------	-------------	-------	----	----	----



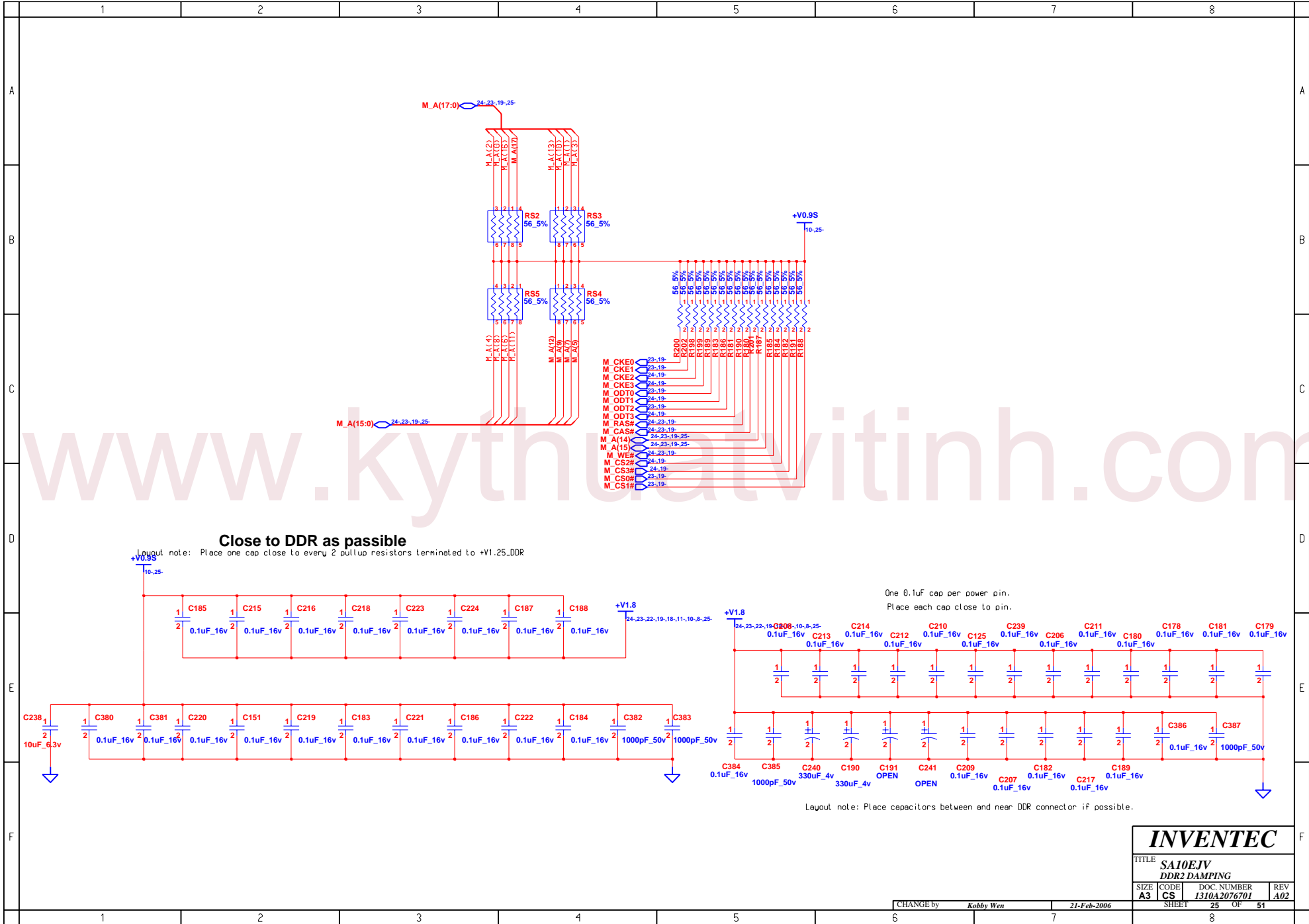

<b>INVENTEC</b>			
TITLE <b>SA10EJV</b> <b>DDR2 DAMPING</b>			
SIZE <b>A3</b>	CODE <b>CS</b>	DOC. NUMBER <b>1310A2076701</b>	REV <b>A02</b>
CHANGE by <i>Kobby Wen</i>		21-Feb-2006	
SHEET <b>25</b>		OF <b>51</b>	

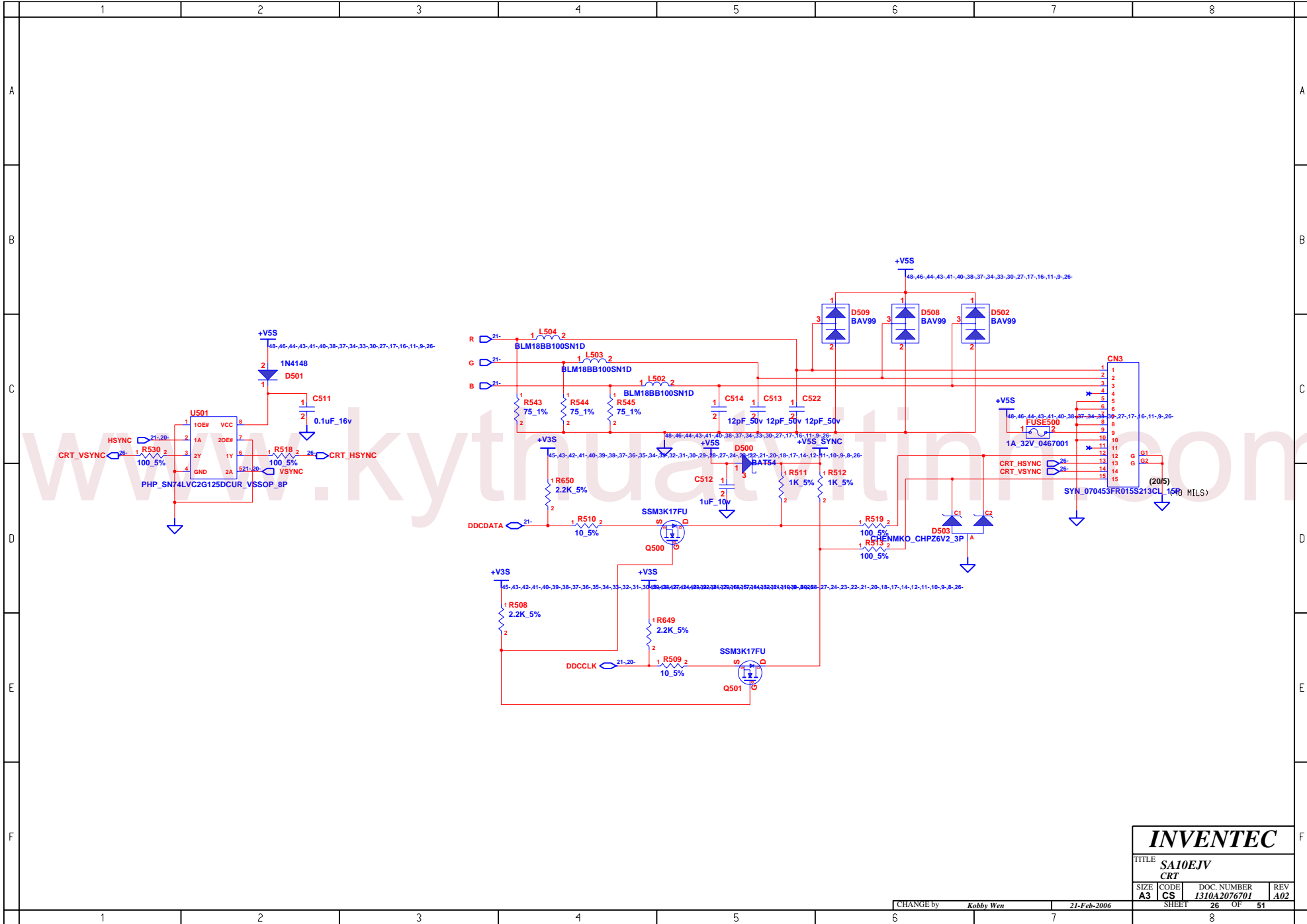

# INVENTEC

TITLE  
SA10EJV  
CRT

SIZE A3	CODE CS	DOC. NUMBER 1310A2076701	REV A02
------------	------------	-----------------------------	------------

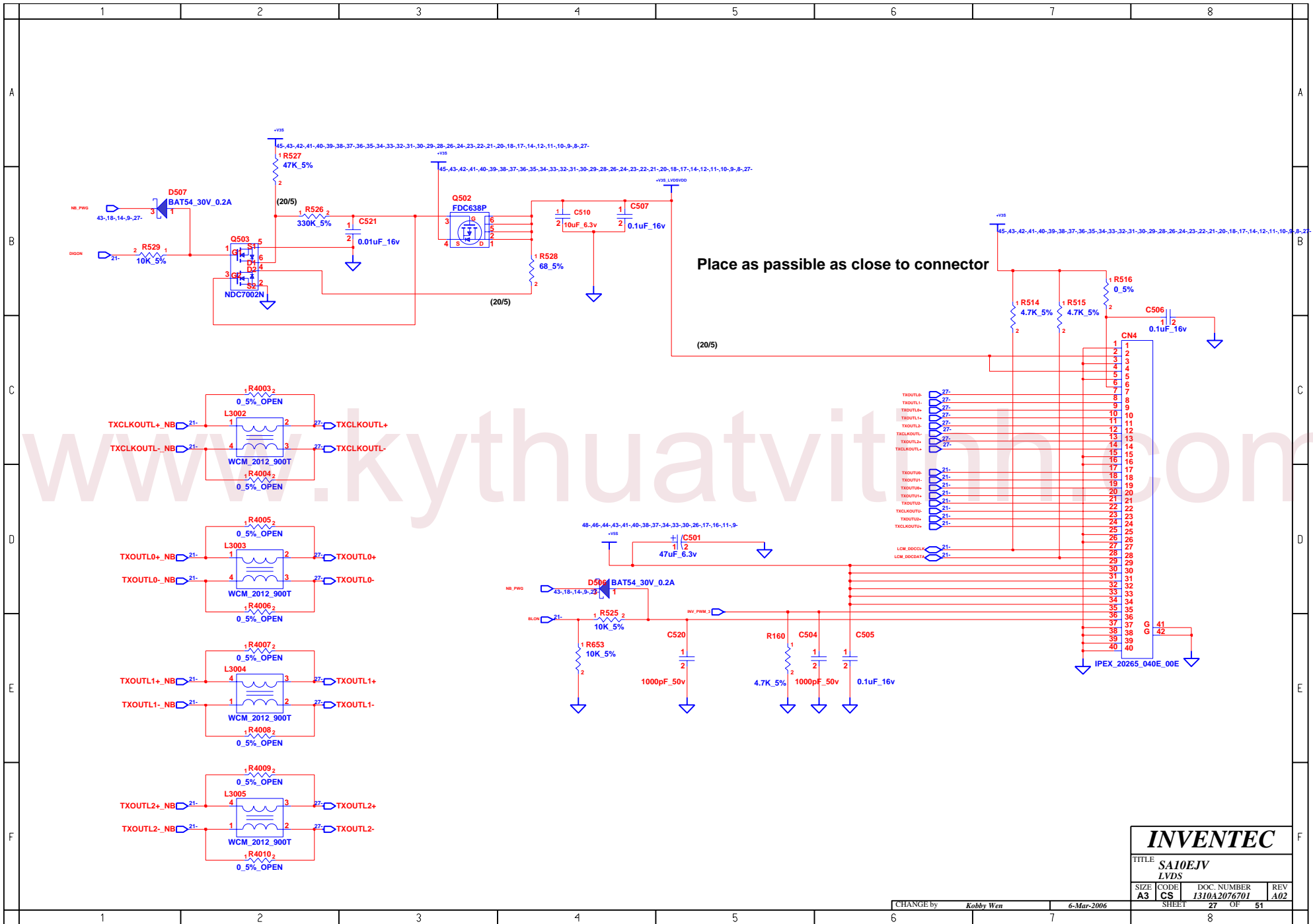

Place as possible as close to connector

<b>INVENTEC</b>			
TITLE SA10EJV			
LVDS			
SIZE A3	CODE CS	DOC. NUMBER 1310A2076701	REV A02
CHANGE by Kobby Wen		6-Mar-2006	SHEET 27 OF 51

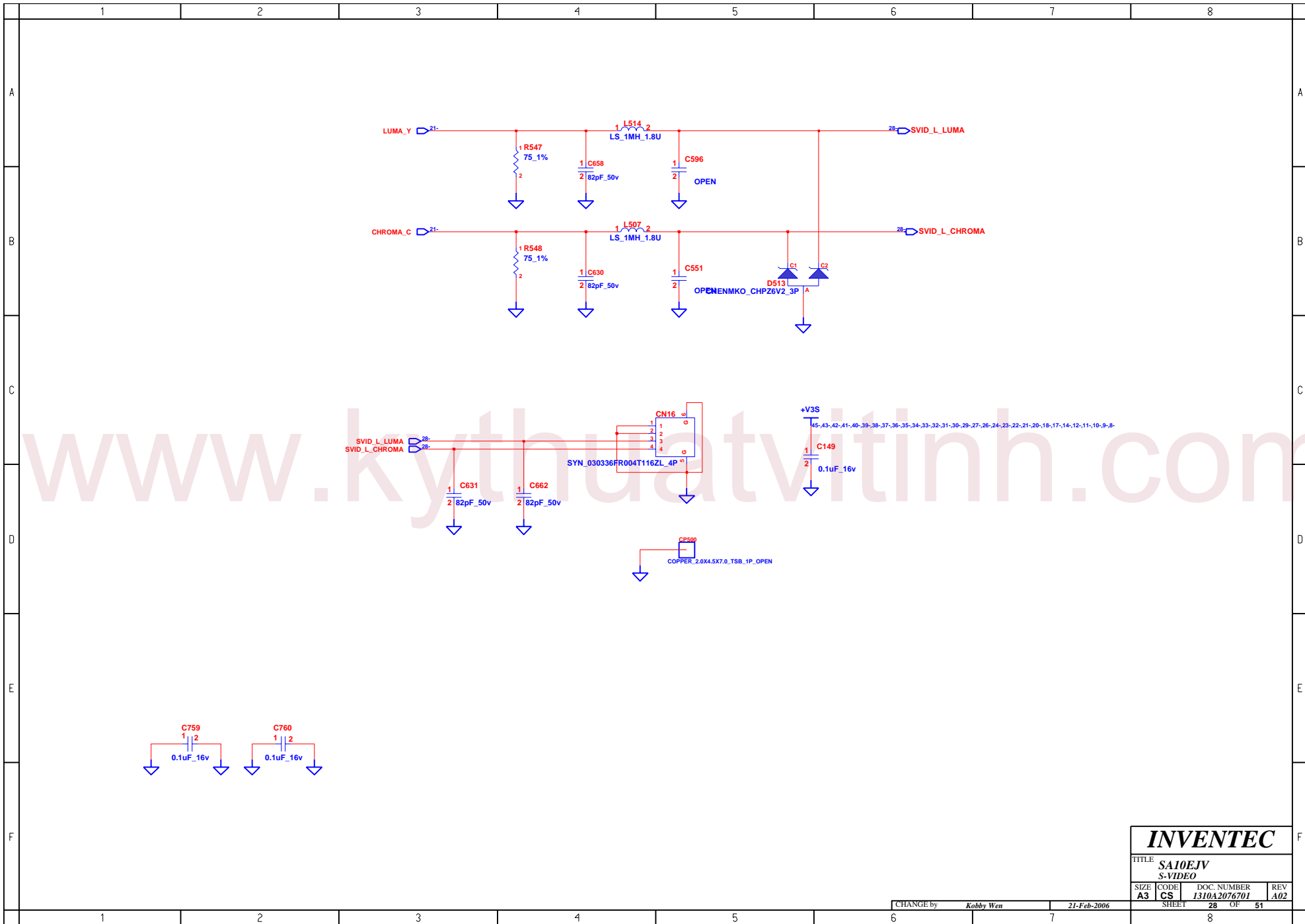

**INVENTEC**

TITLE			
SA10EJV			
S-VIDEO			
SIZE	CODE	DOC. NUMBER	REV
A3	CS	1310A2076701	A02

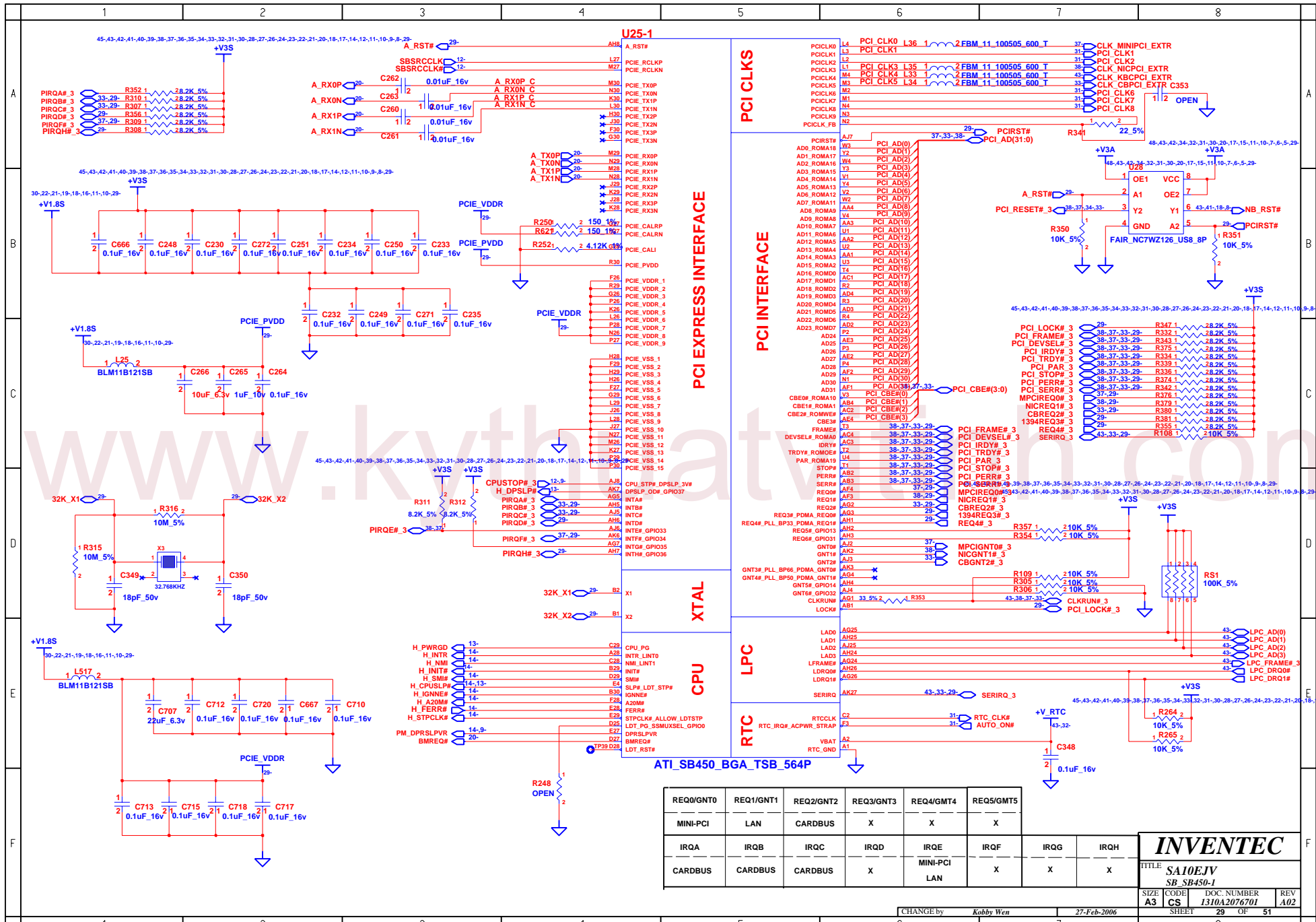

REQ0/GNT0	REQ1/GNT1	REQ2/GNT2	REQ3/GNT3	REQ4/GMT4	REQ5/GMT5
MINI-PCI	LAN	CARDBUS	X	X	X
IRQA	IRQB	IRQC	IRQD	IRQE	IRQF
CARDBUS	CARDBUS	CARDBUS	X	MINI-PCI LAN	X
					X
					X

**INVENTEC**

TITLE  
SA10EJV  
SB\_SB450-1

SIZE CODE DOC. NUMBER  
A3 CS 1310A2076701  
SHEET 29 OF 51  
REV A02

CHANGE by Kobby Wen 27-Feb-2006

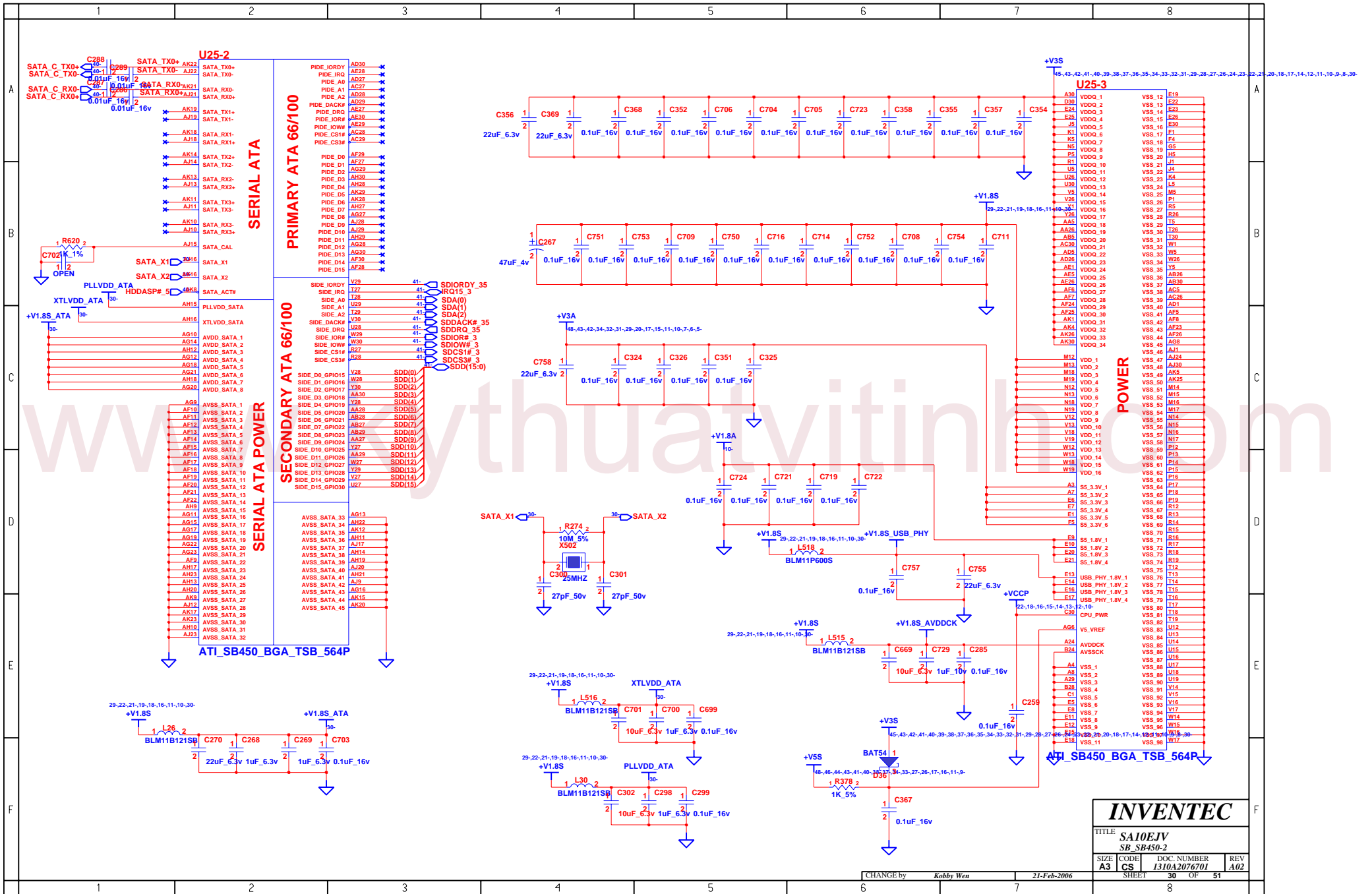

**INVENTEC**

TITLE  
**SA10EJV**  
**SB\_SB450-2**

SIZE <b>A3</b>	CODE <b>CS</b>	DOC. NUMBER <b>1310A2076701</b>	REV <b>A02</b>
SHEET <b>8</b>		OF <b>51</b>	

CHANGE by *Kobby Wen* 21-Feb-2006

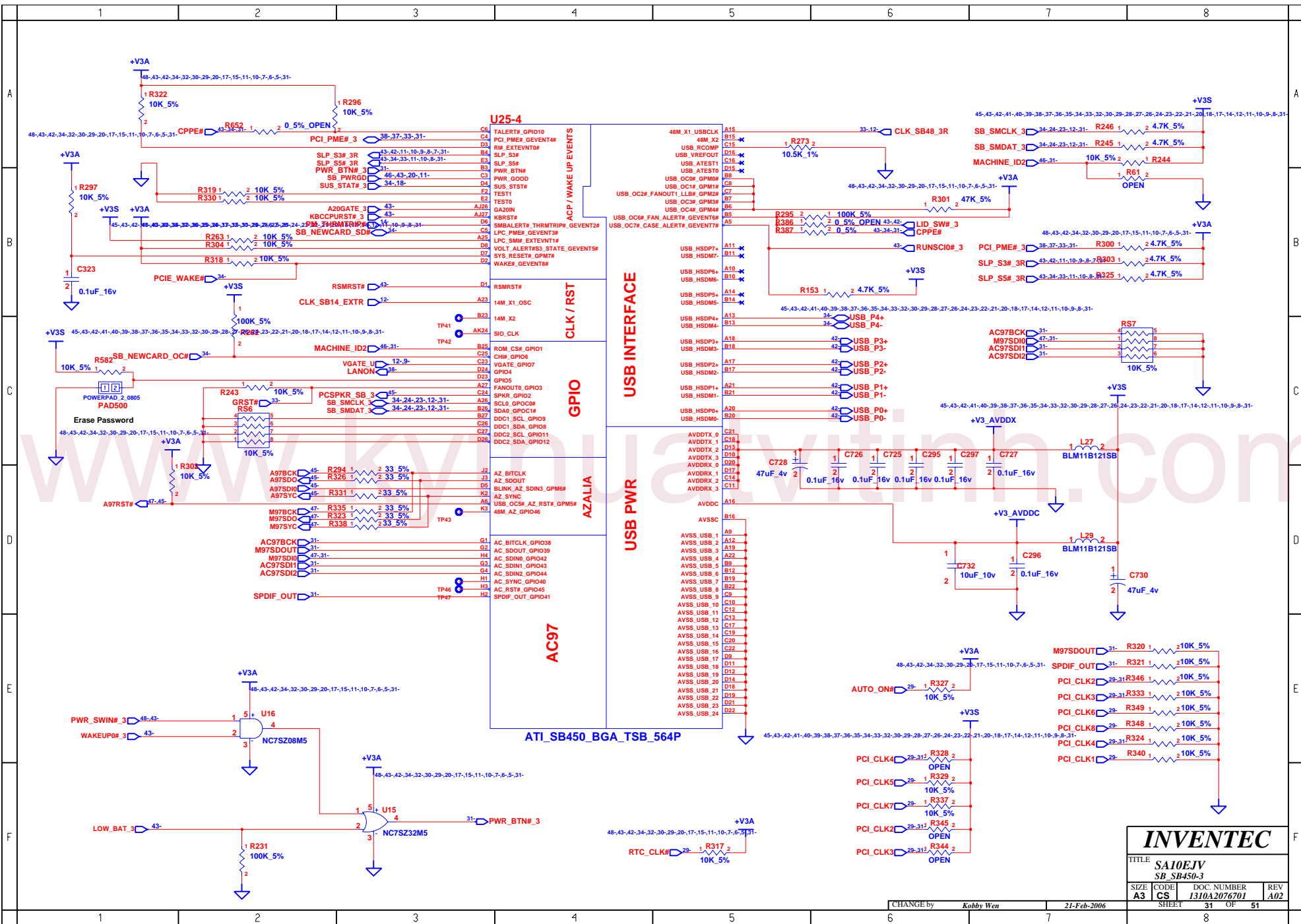

# INVENTEC

TITLE: SA10EJV  
SB\_SB450-3

SIZE	CODE	DOC. NUMBER	REV
A3	CS	I310A2076701	A02

CHANGE by: Kobby Wen 21-Feb-2006

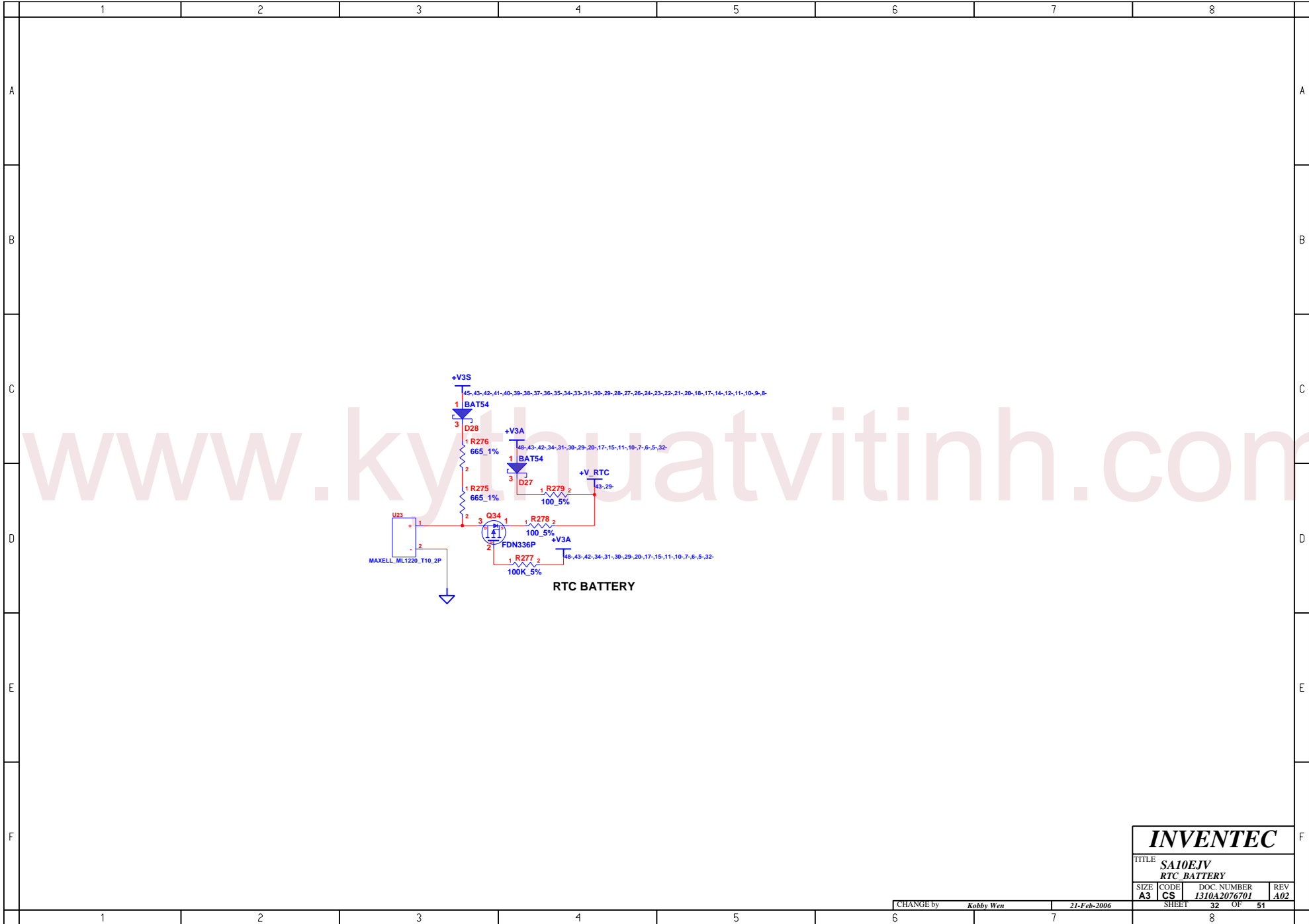

RTC BATTERY

**INVENTEC**

TITLE **SA10EJV**  
**RTC BATTERY**

SIZE <b>A3</b>	CODE <b>CS</b>	DOC. NUMBER <b>1310A2076701</b>	REV <b>A02</b>
-------------------	-------------------	------------------------------------	-------------------

CHANGE by *Kobby Wen* 21-Feb-2006

SHEET 32 OF 51



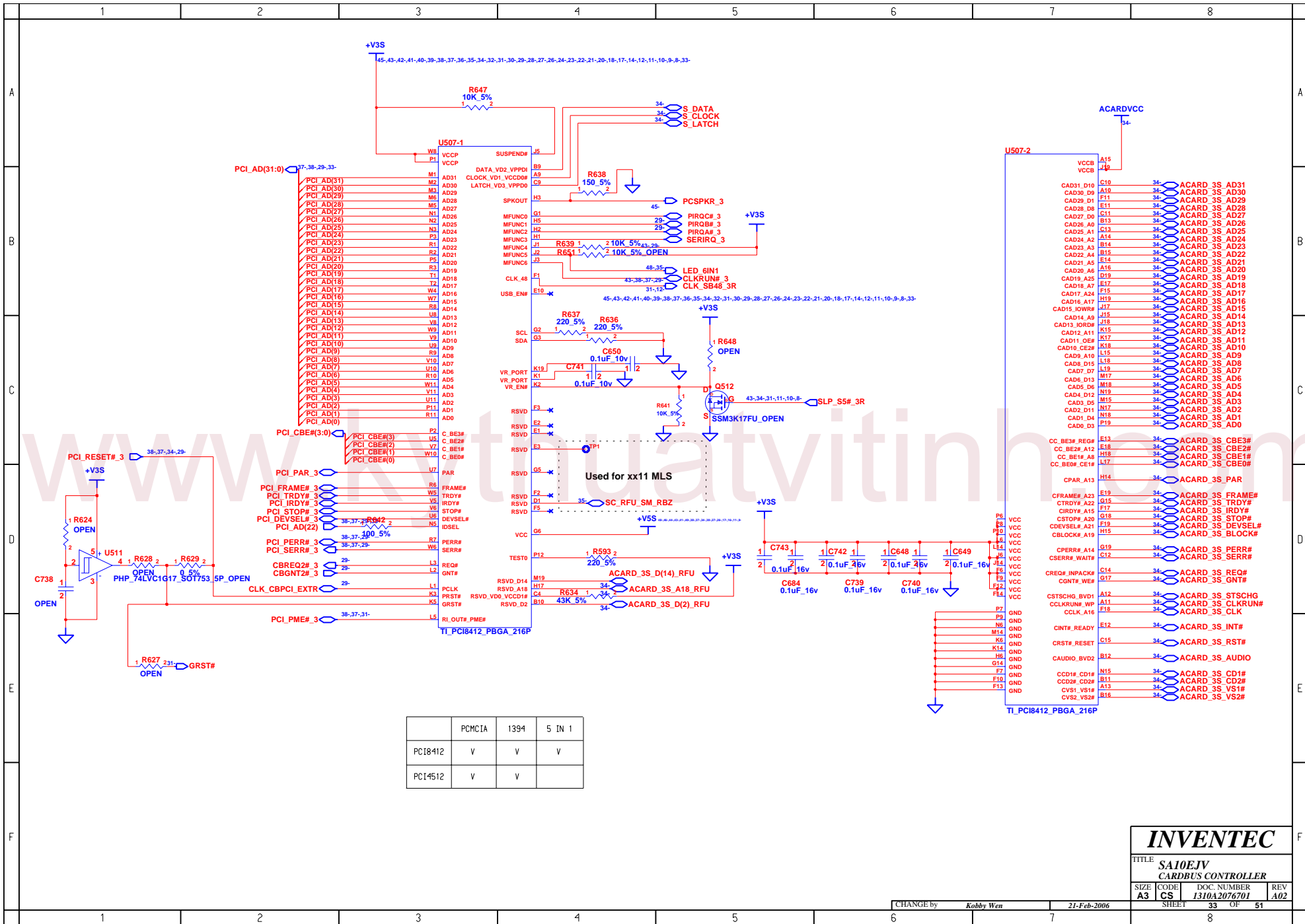

	PCMCIA	1394	5 IN 1
PC18412	V	V	V
PC14512	V	V	

<b>INVENTEC</b>			
TITLE <b>SA10EJV CARBUS CONTROLLER</b>			
SIZE <b>A3</b>	CODE <b>CS</b>	DOC. NUMBER <b>1310A2076701</b>	REV <b>A02</b>
CHANGE by <i>Kobby Wen</i>		21-Feb-2006	
SHEET <b>33</b>		OF <b>51</b>	

R654  
4.7K\_5%

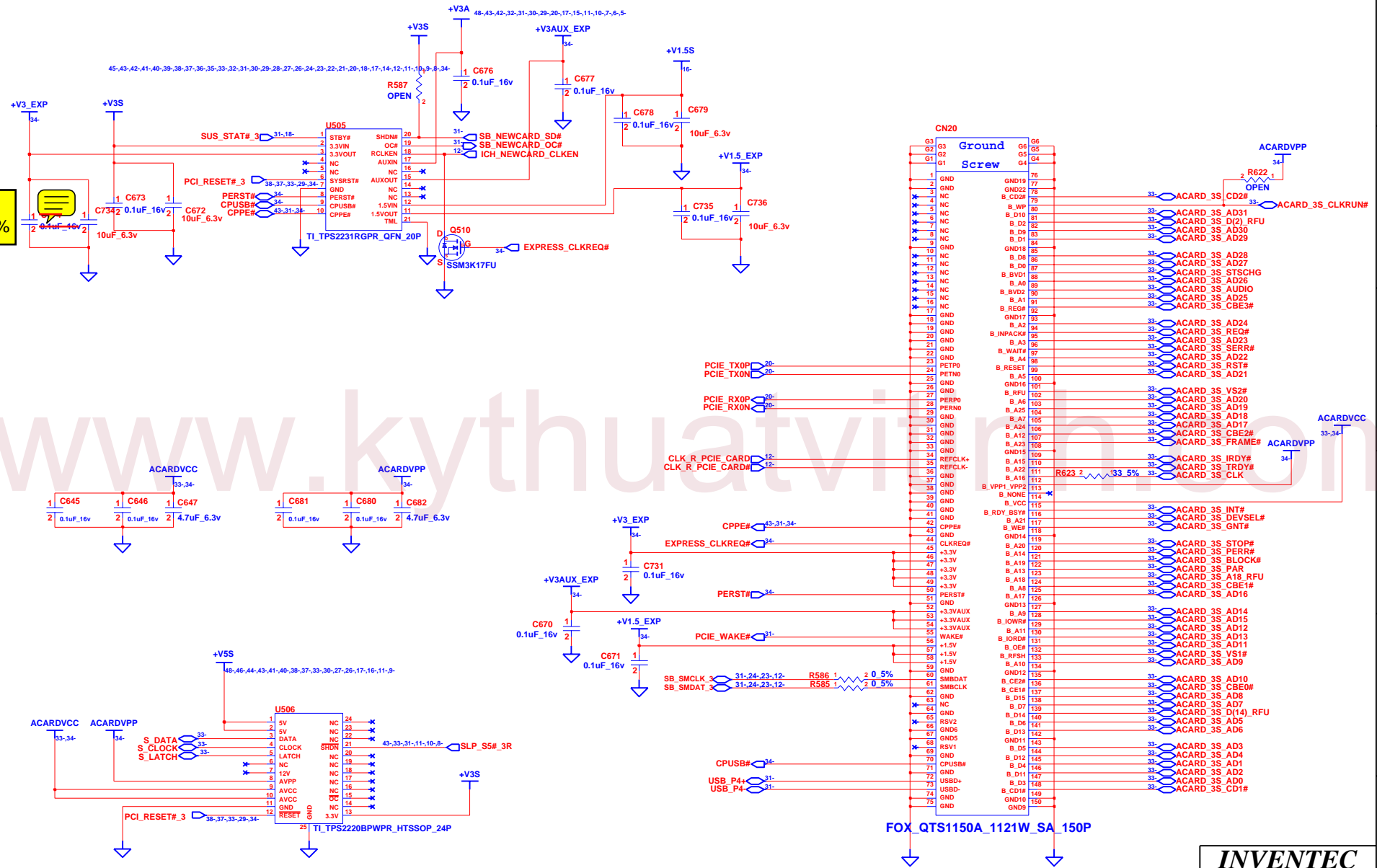

<b>INVENTEC</b>			
TITLE SA10EJV PCMCIA & EXPRESS CARD			
SIZE A3	CODE CS	DOC. NUMBER I310A2076701	REV A02
CHANGE by Kobby Wen		21-Feb-2006	
SHEET 34		OF 51	

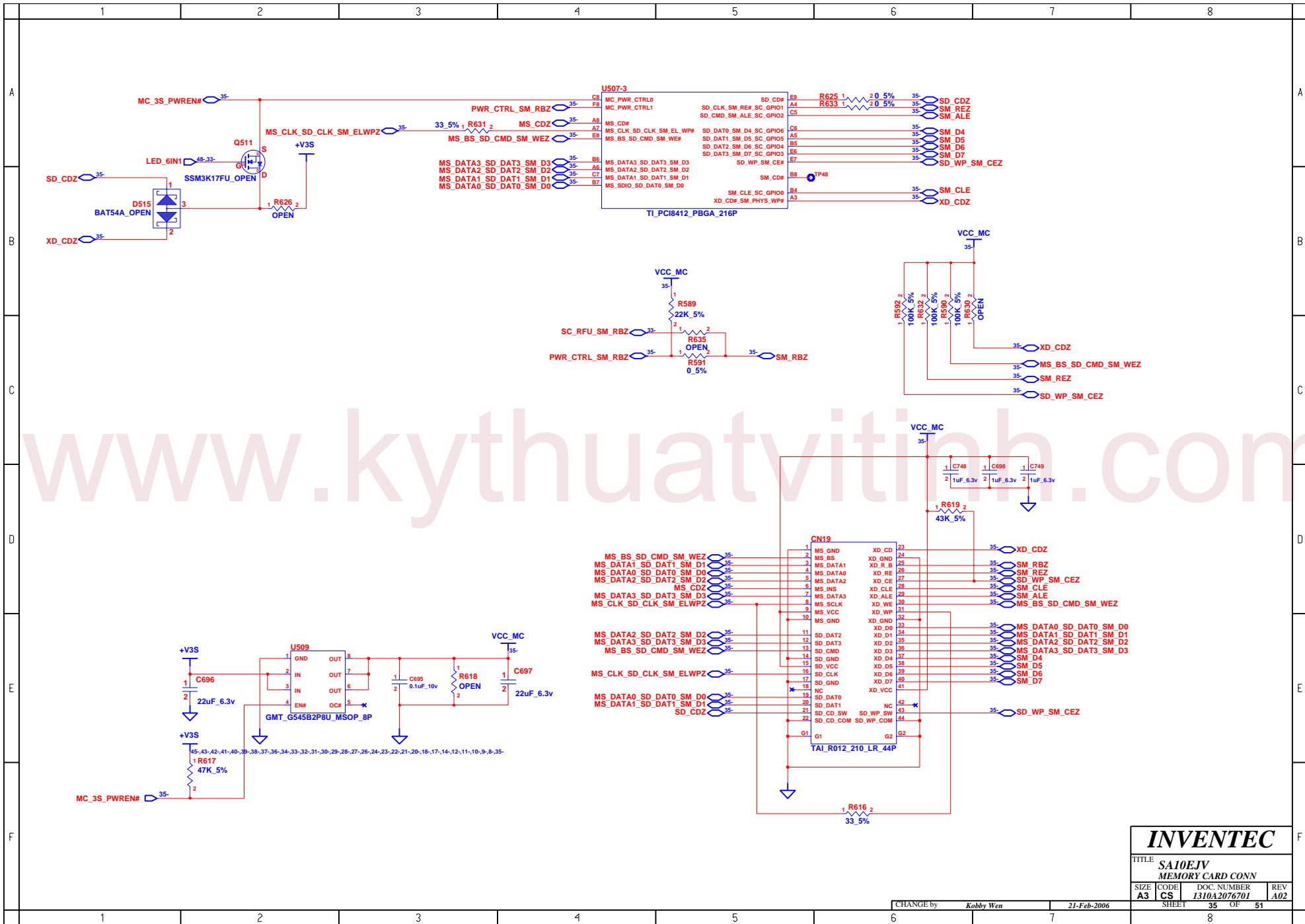

# INVENTEC

TITLE: SA10EJV  
MEMORY CARD CONN

SIZE	CODE	DOC. NUMBER	REV
A3	CS	1310A2076701	A02

CHANGE by: Kobby Wen 21-Feb-2006

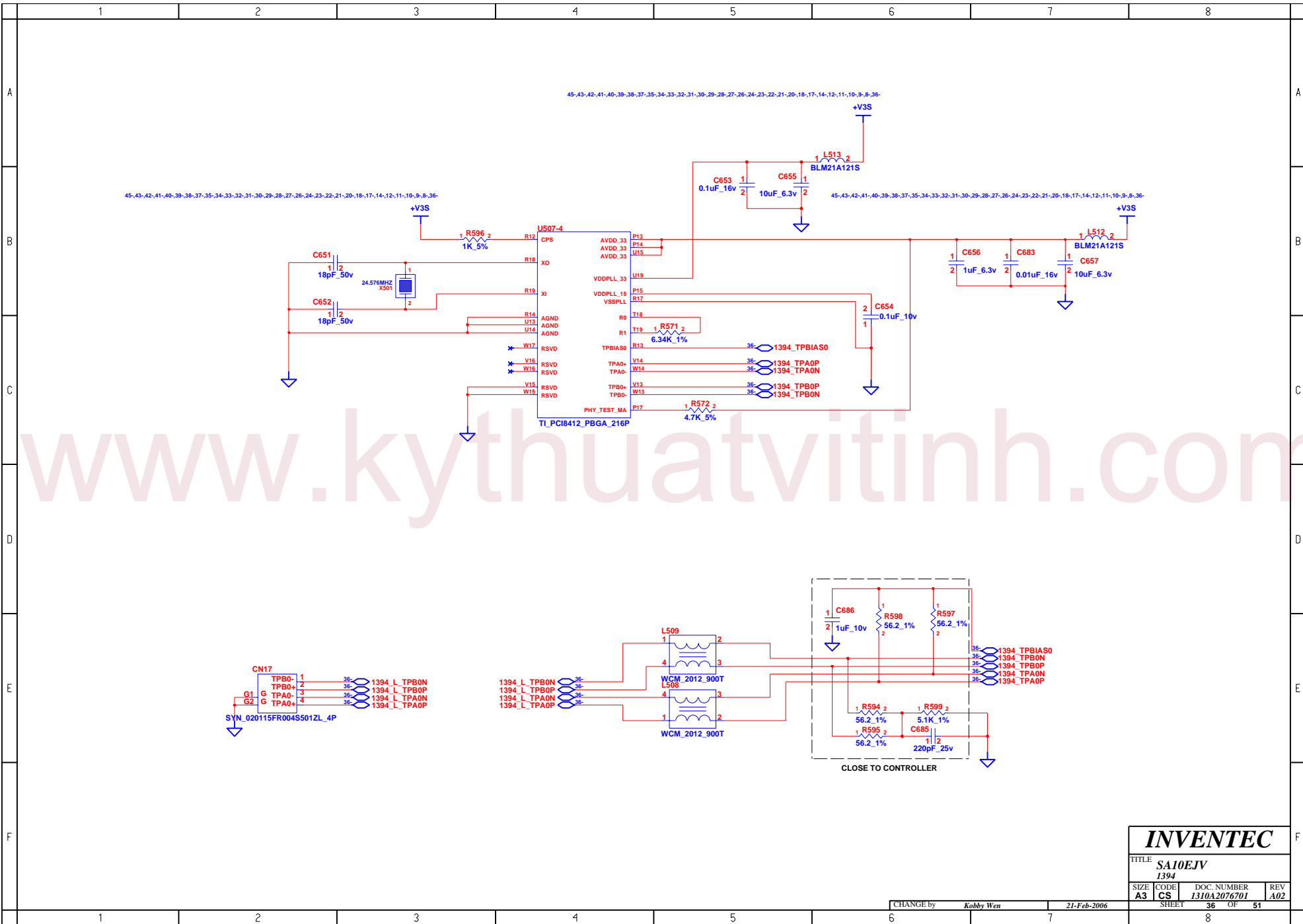

www.kythuatchitinh.com

**INVENTEC**

TITLE  
SA10EJV  
1394

SIZE A3	CODE CS	DOC. NUMBER 1310A2076701	REV A02
------------	------------	-----------------------------	------------

CHANGE by *Kobby Wen* 21-Feb-2006  
SHEET 36 OF 51

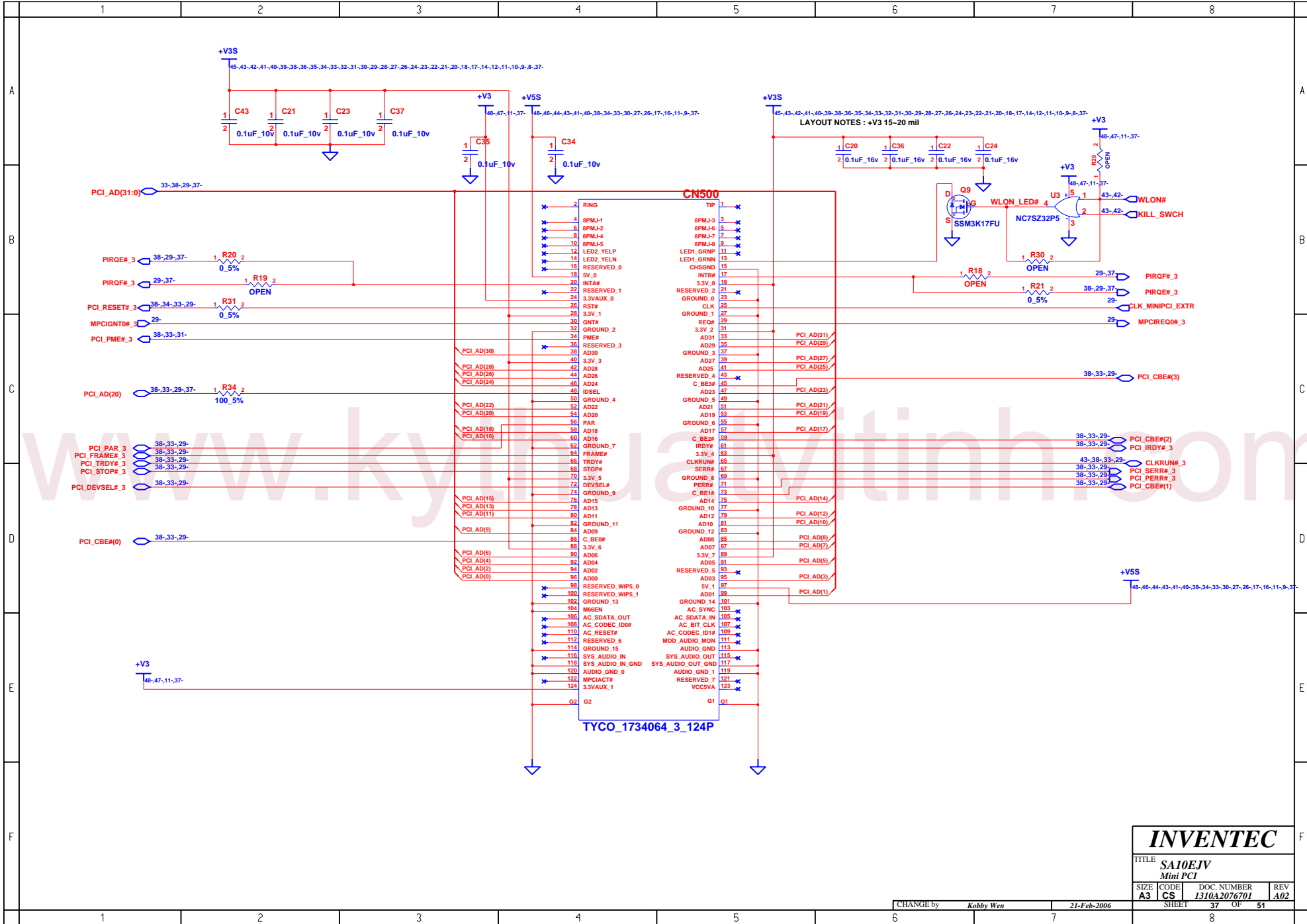

<b>INVENTEC</b>			
TITLE SA10EJV Mini PCI			
SIZE A3	CODE CS	DOC. NUMBER 1310A2076701	REV A02
CHANGE by Kobby Wen		21-Feb-2006	
SHEET 37		OF 51	

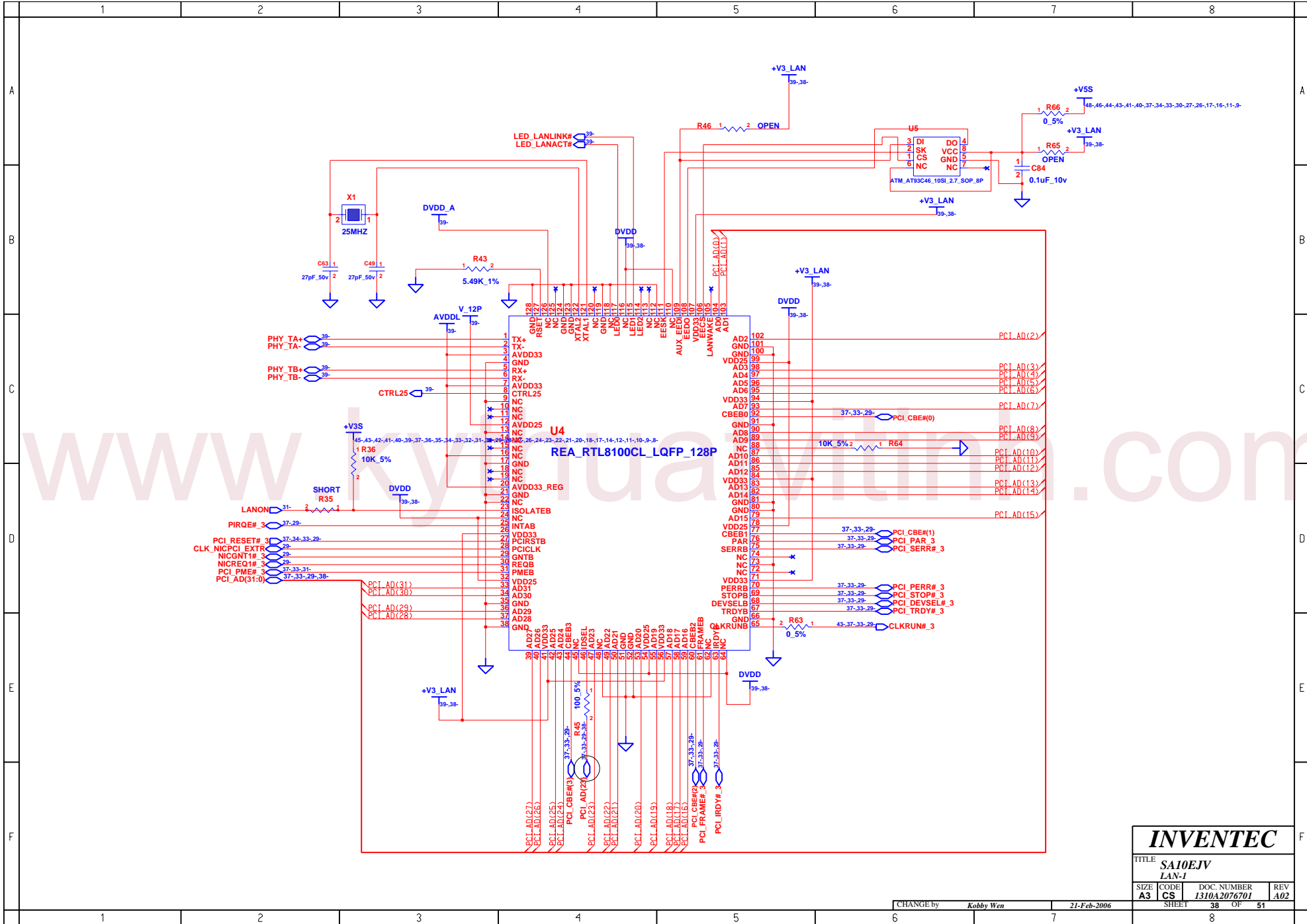

**INVENTEC**

TITLE  
SA10EJV  
LAN-1

SIZE	CODE	DOC. NUMBER	REV
A3	CS	1310A2076701	A02

CHANGE by Kobby Wen 21-Feb-2006

SHEET 38 OF 51

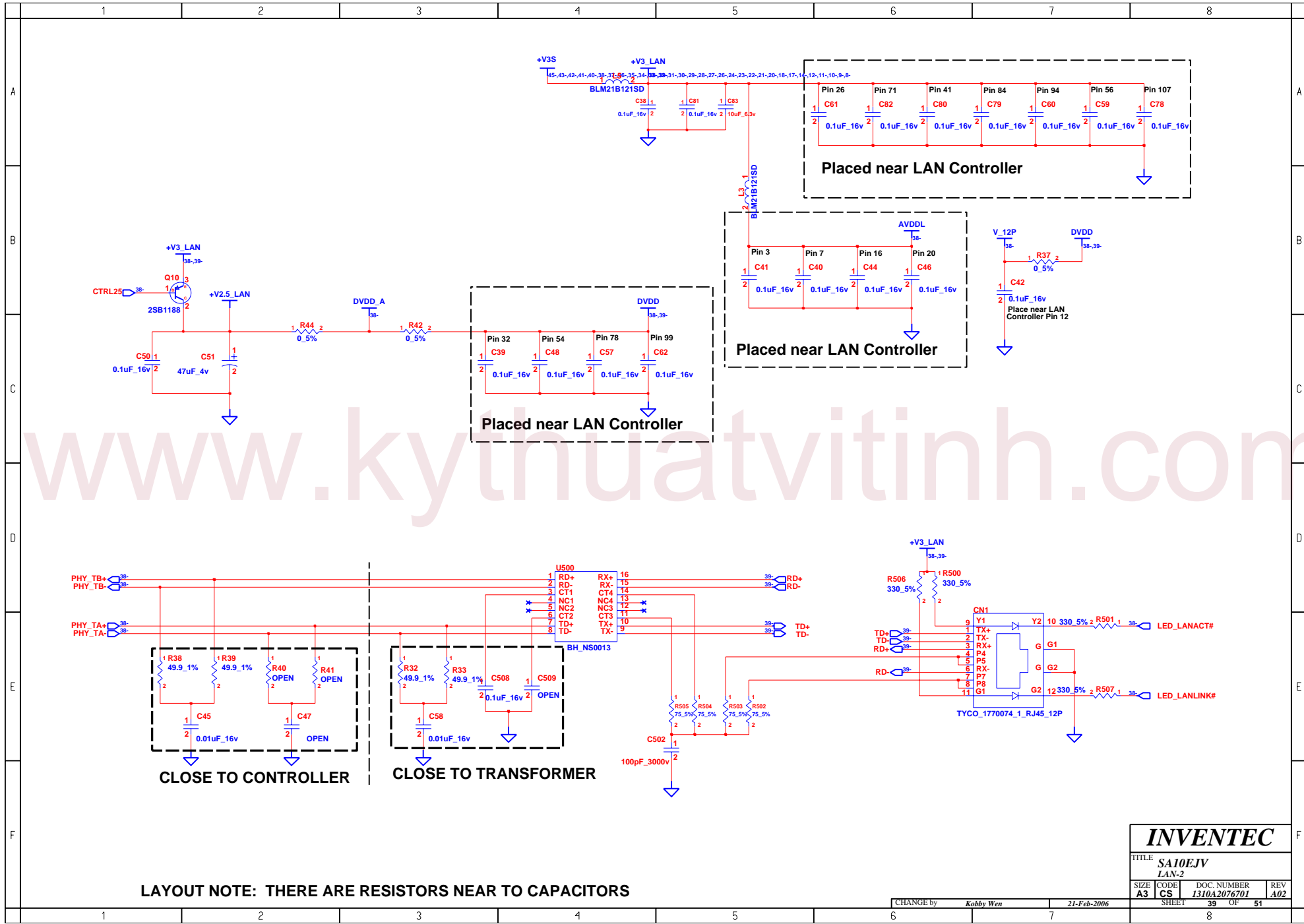

LAYOUT NOTE: THERE ARE RESISTORS NEAR TO CAPACITORS

**INVENTEC**

TITLE			
SA10EJV			
LAN-2			
SIZE	CODE	DOC. NUMBER	REV
A3	CS	1310A2076701	A02

CHANGE by	Kobby Wen	21-Feb-2006	SHEET	39	OF	51
-----------	-----------	-------------	-------	----	----	----

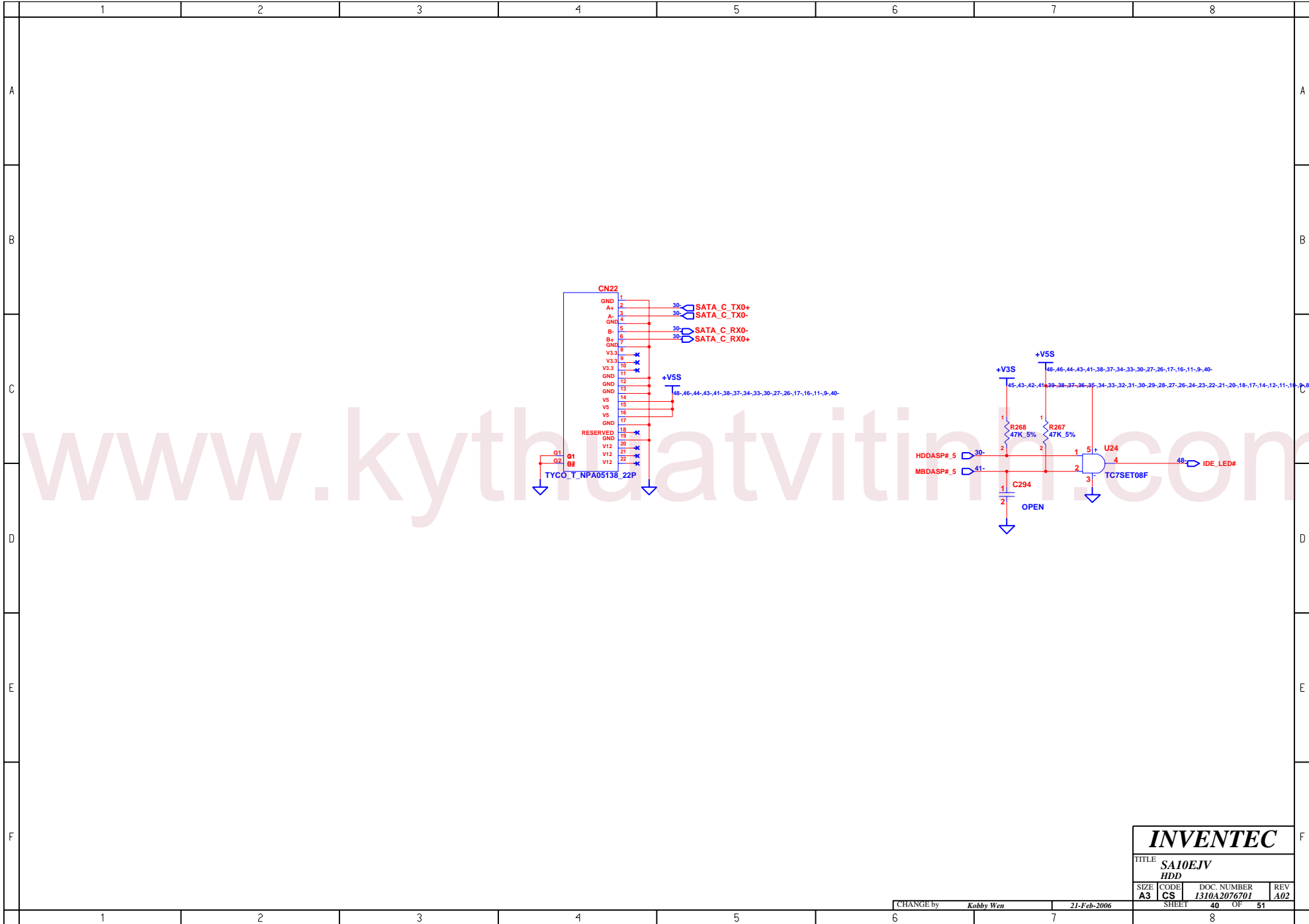

**INVENTEC**

TITLE			
SA10EJV			
HDD			
SIZE	CODE	DOC. NUMBER	REV
A3	CS	1310A2076701	A02



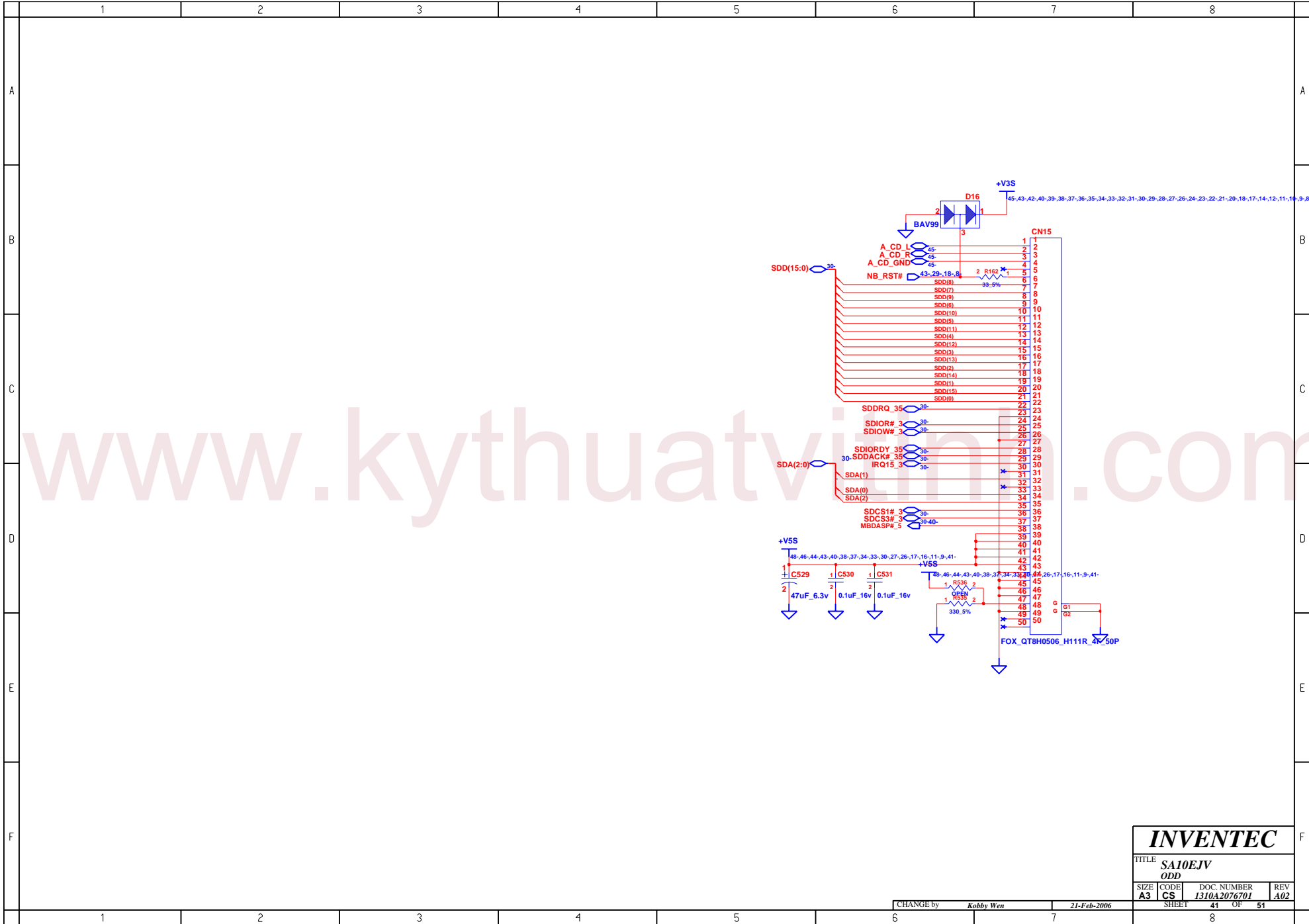

**INVENTEC**

TITLE **SA10EJV**  
**ODD**  
 SIZE **A3** CODE **CS** DOC. NUMBER **1310A2076701** REV **A02**

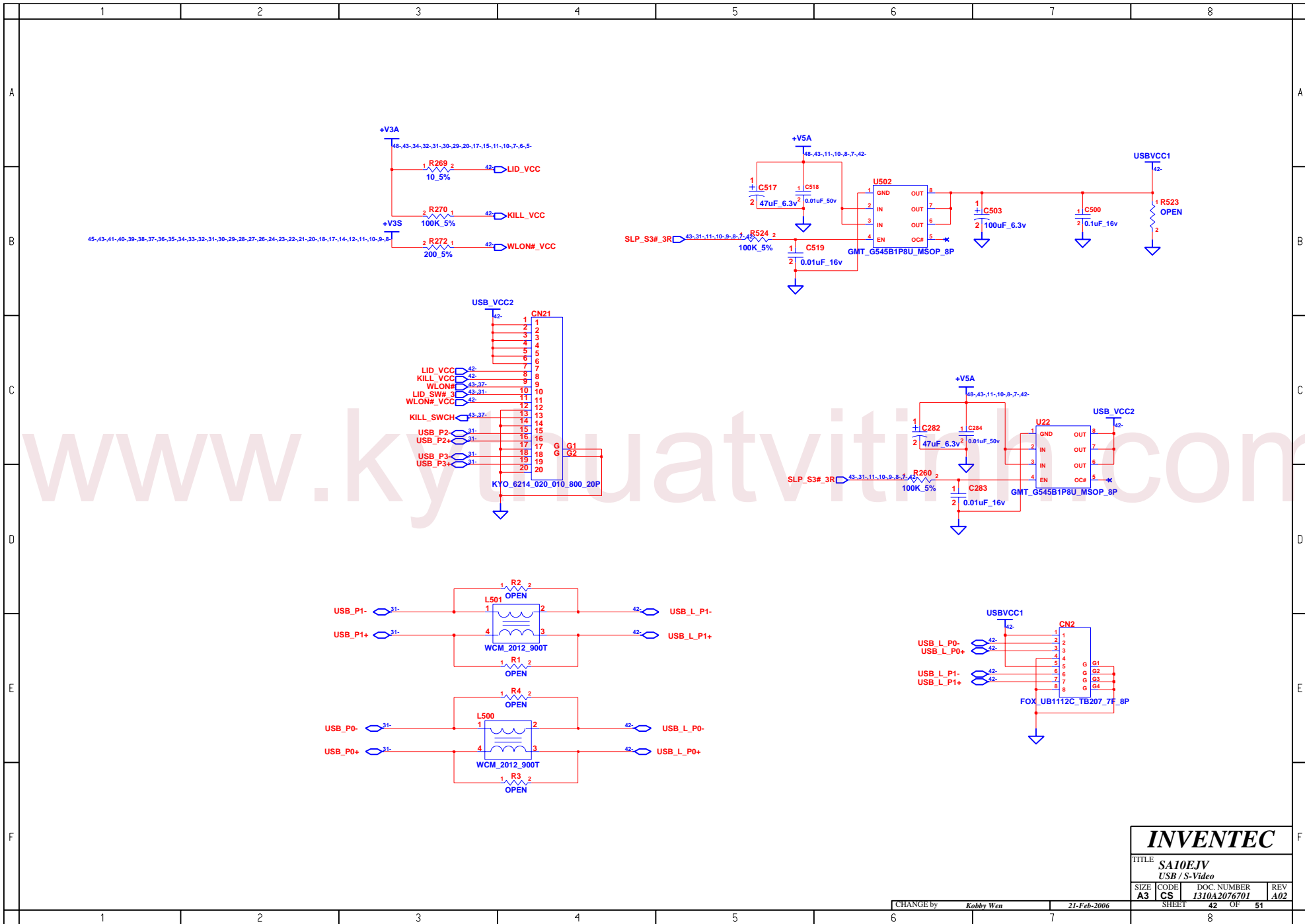

**INVENTEC**

TITLE  
**SA10EJV**  
 USB / S-Video

SIZE <b>A3</b>	CODE <b>CS</b>	DOC. NUMBER <b>I310A2076701</b>	REV <b>A02</b>
-------------------	-------------------	------------------------------------	-------------------

CHANGE by *Kobby Wen* 21-Feb-2006

SHEET 42 OF 51

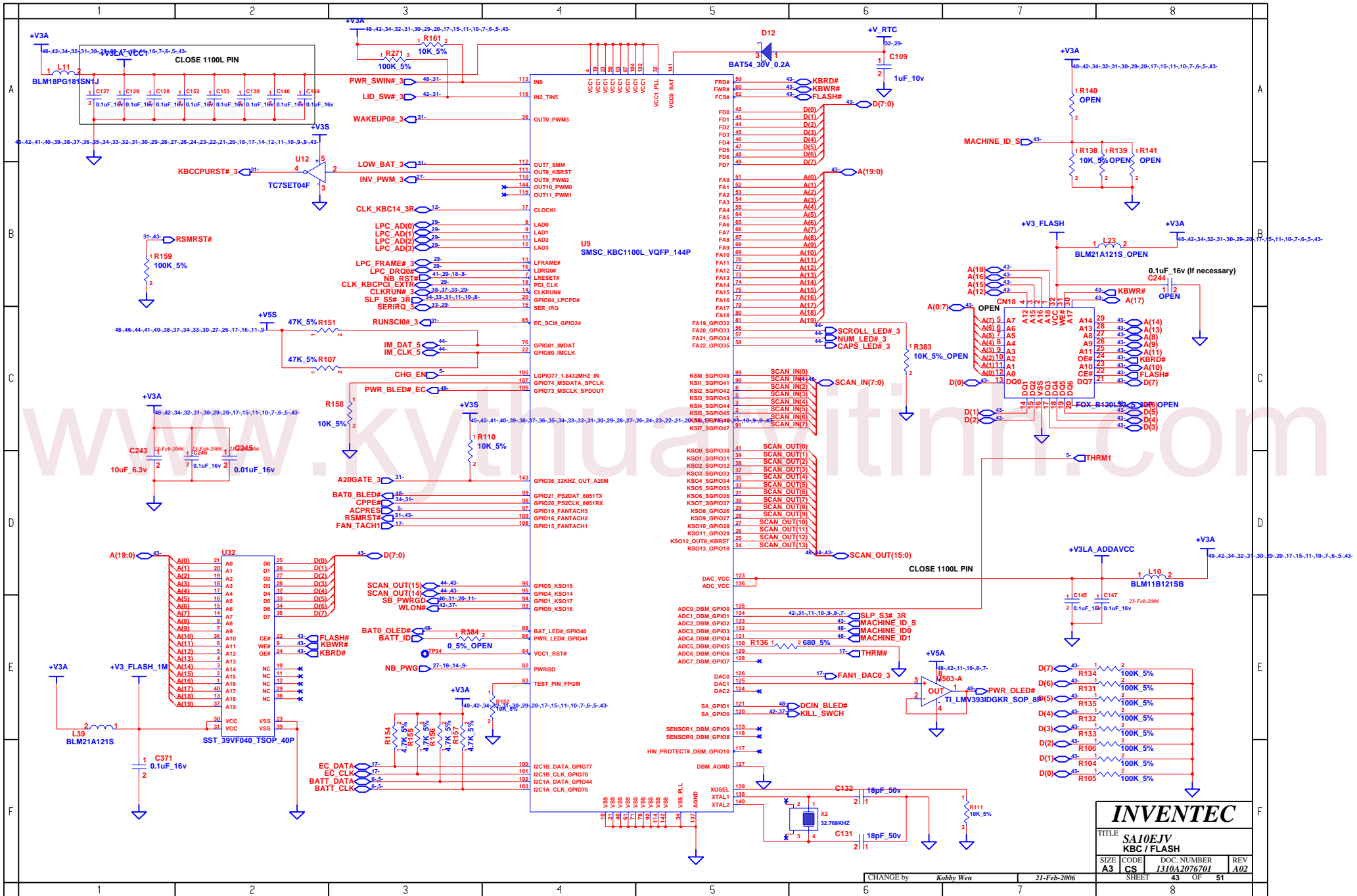

**INVENTEC**

TITLE SA10EJV  
KBC / FLASH

SIZE A3	CODE CS	DOC. NUMBER 1310A2076701	REV A02
SHEET 43		OF 51	

CHANGE by Kobby Wen 21-Feb-2006

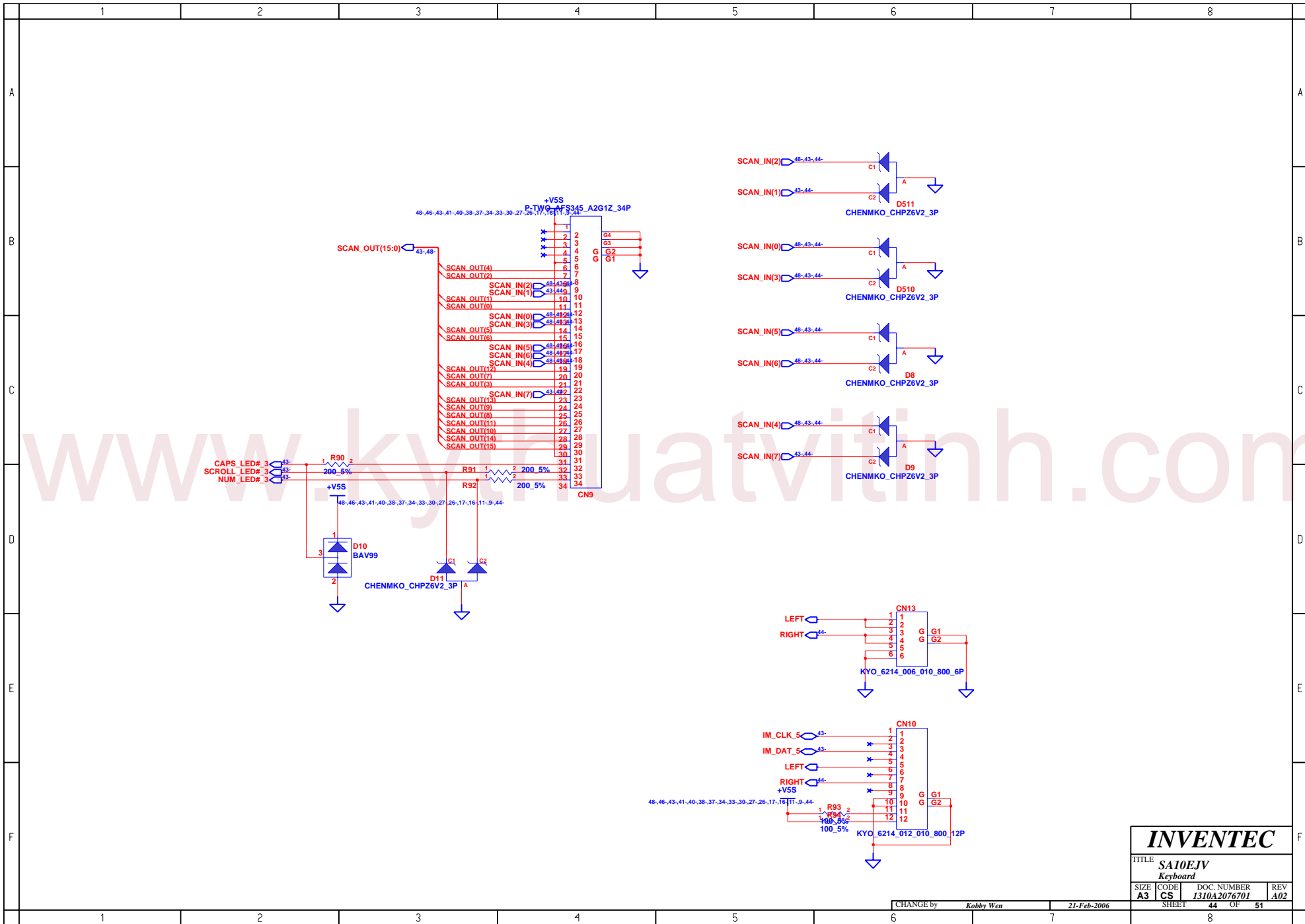

www.kyocera.com

# INVENTEC

TITLE SA10EJV  
Keyboard

SIZE A3	CODE CS	DOC. NUMBER 1310A2076701	REV A02
------------	------------	-----------------------------	------------

CHANGE by Kobby Wen 21-Feb-2006

SHEET 44 OF 51

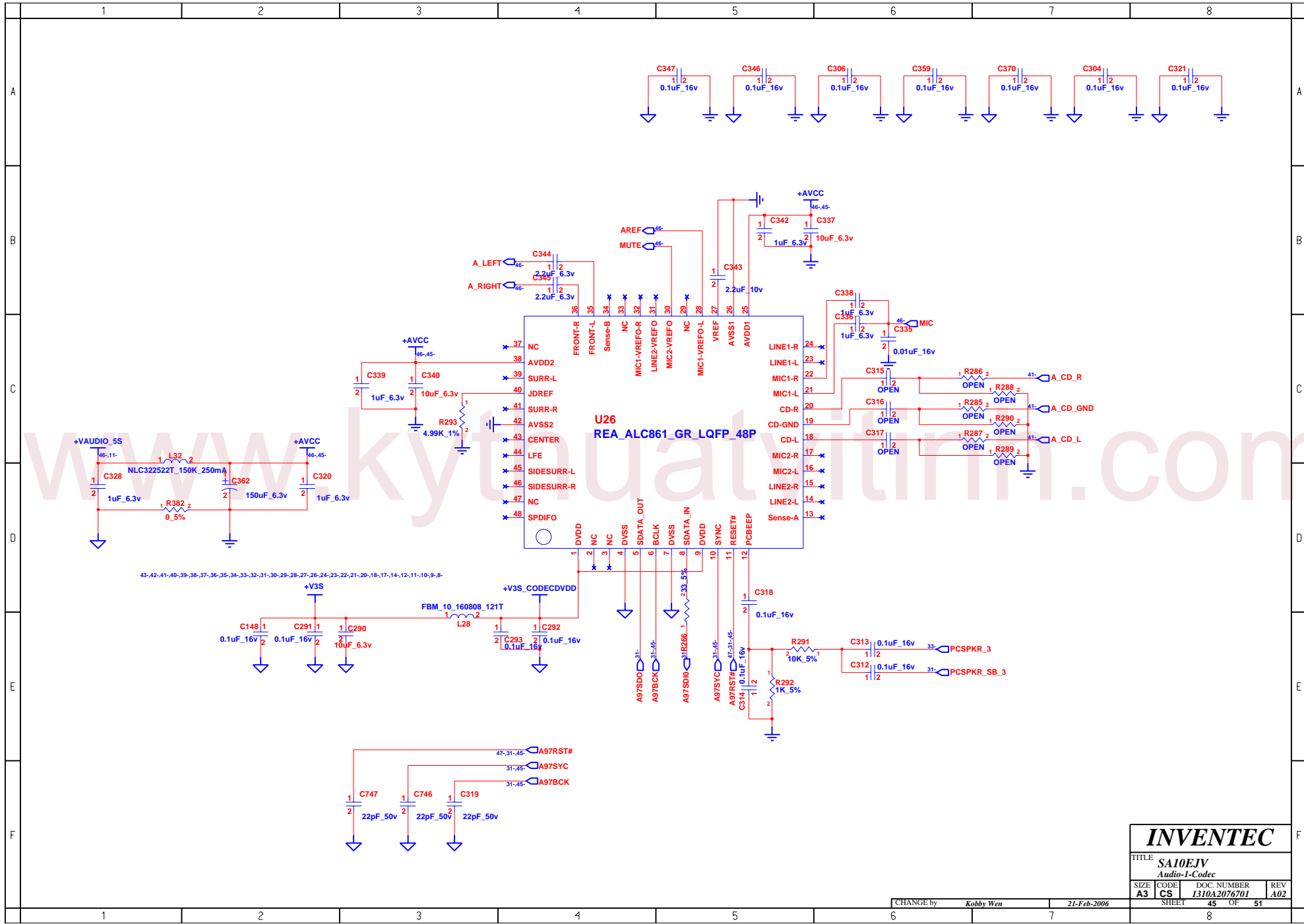

**INVENTEC**

TITLE			
SA10EJV			
Audio-1-Codec			
SIZE	CODE	DOC. NUMBER	REV
A3	CS	I310A2076701	A02
CHANGE by		SHEET	
Kobby Wen		45 OF 51	

21-Feb-2006

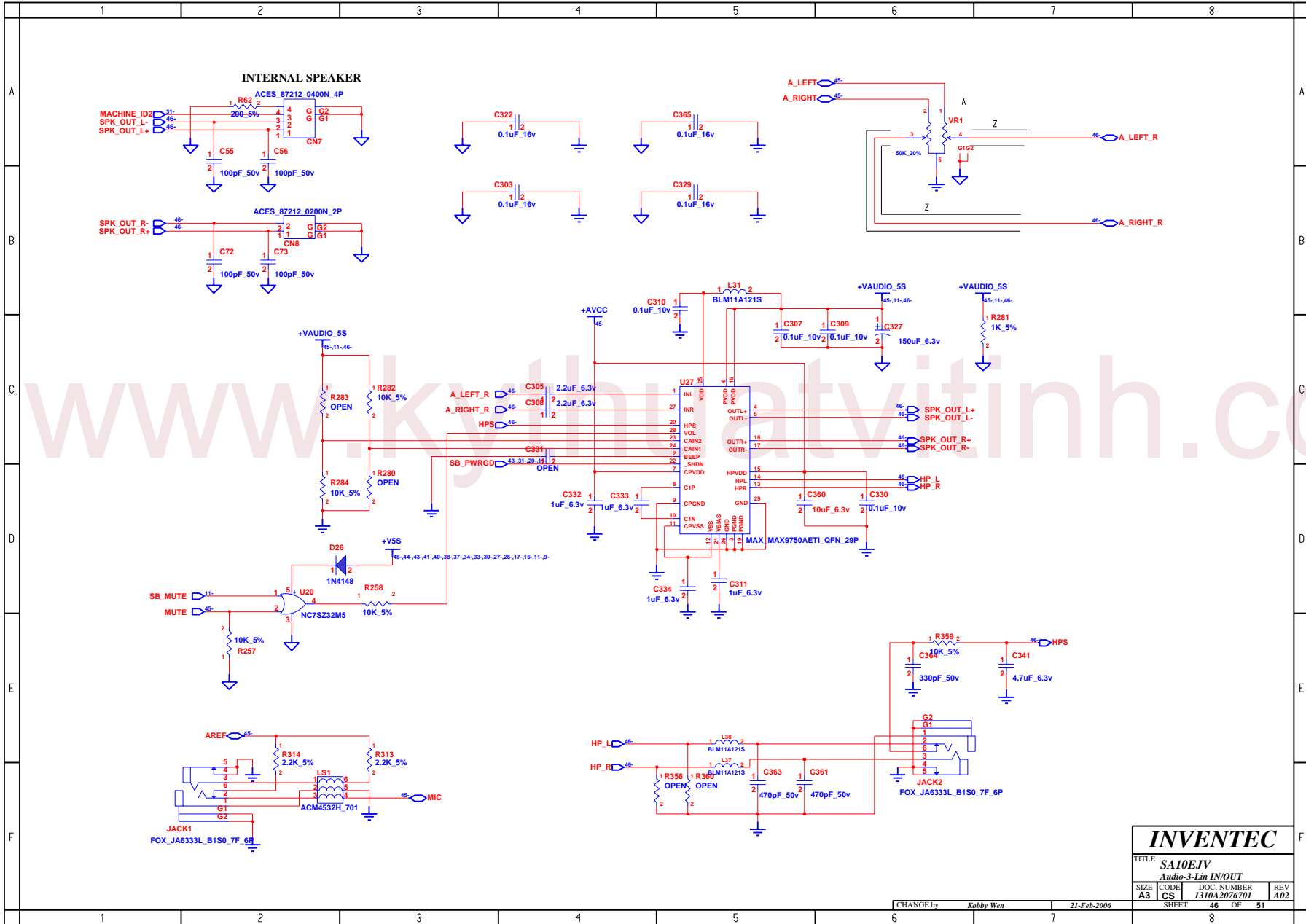

<b>INVENTEC</b>			
TITLE: SA10EJV			
Audio-3-Lin IN/OUT			
SIZE	CODE	DOC. NUMBER	REV
A3	CS	1310A2076701	A02

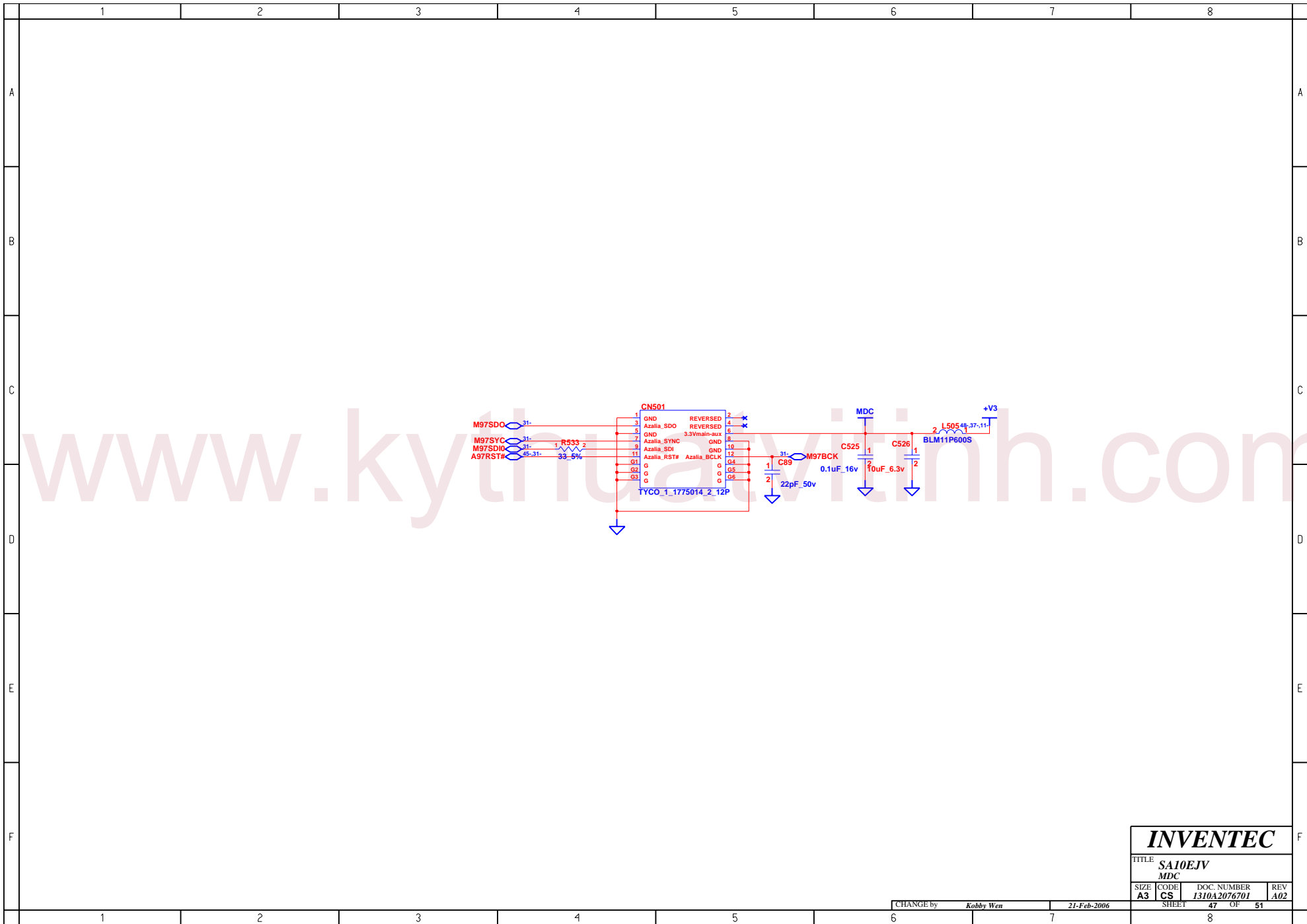

**INVENTEC**

TITLE **SA10EJV**  
**MDC**

SIZE <b>A3</b>	CODE <b>CS</b>	DOC. NUMBER <b>1310A2076701</b>	REV <b>A02</b>
-------------------	-------------------	------------------------------------	-------------------

CHANGE by *Kobby Wen* 21-Feb-2006

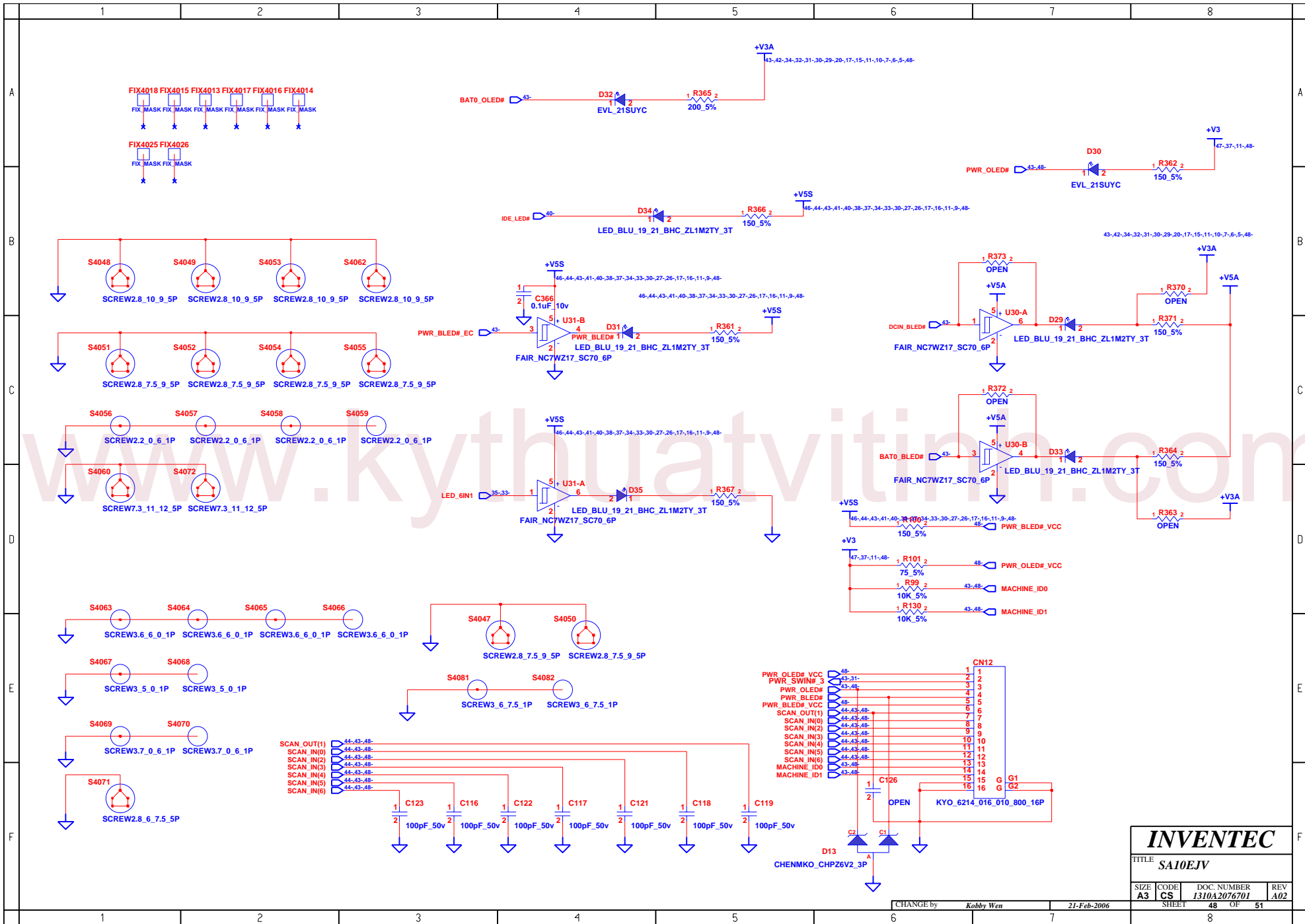

<b>INVENTEC</b>			
TITLE <b>SA10EJV</b>			
SIZE <b>A3</b>	CODE <b>CS</b>	DOC. NUMBER <b>1310A2076701</b>	REV <b>A02</b>
CHANGE by <i>Kobby Wen</i>		21-Feb-2006	
SHEET <b>48</b>		OF <b>51</b>	



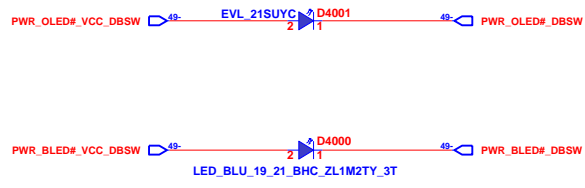

**LED & SWITCH**

**POWER SWITCH**

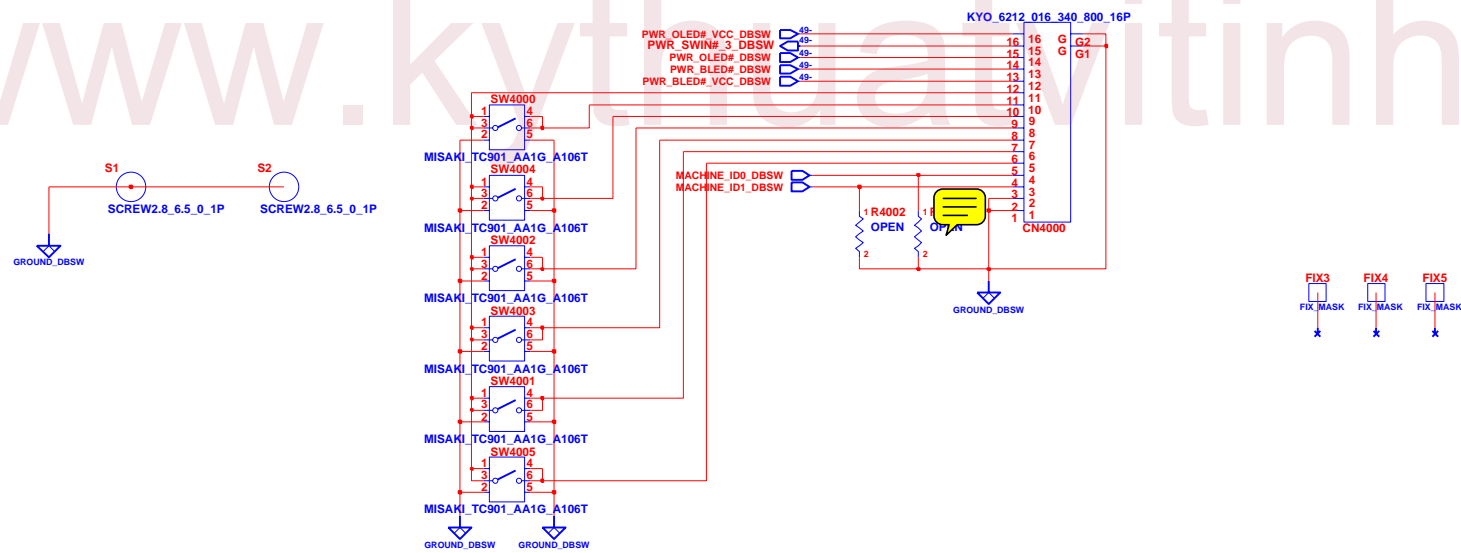

<b>INVENTEC</b>			
TITLE <i>San Antonio 10EJV</i>			
Buttom Board			
SIZE <b>A3</b>	CODE <b>CS</b>	DOC. NUMBER	REV
CHANGE by <b>SA10E</b>		21-Feb-2006	SHEET 49 OF 51
		7	8

# KILL SWITCH

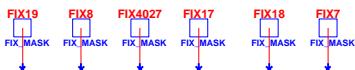
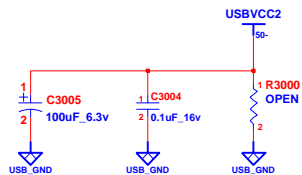
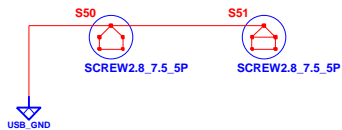
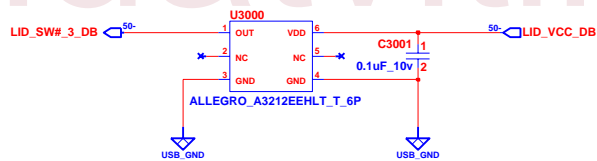
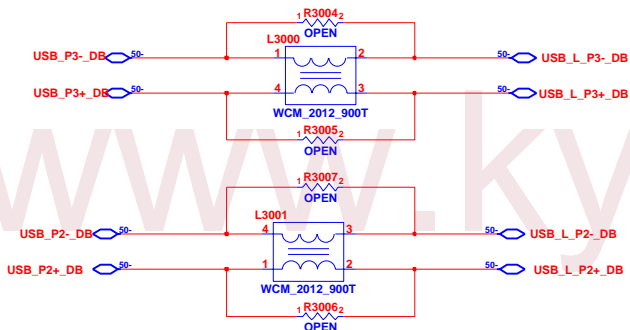
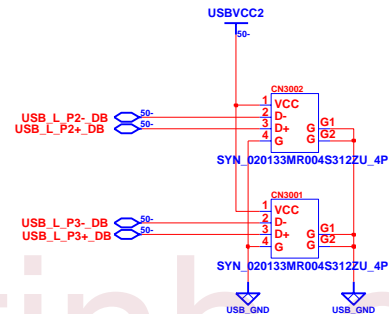
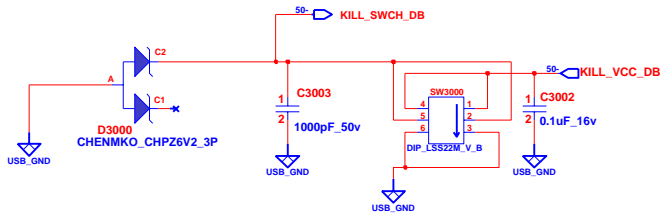
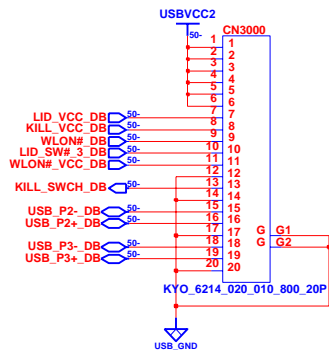

**INVENTEC**

TITLE  
SA10EJV  
USB/1394/SVIDEO Board

SIZE A3	CODE CS	DOC. NUMBER 1310A2076701	REV A02
------------	------------	-----------------------------	------------

CHANGE by Kobby Wen 21-Feb-2006

SHEET 50 OF 51

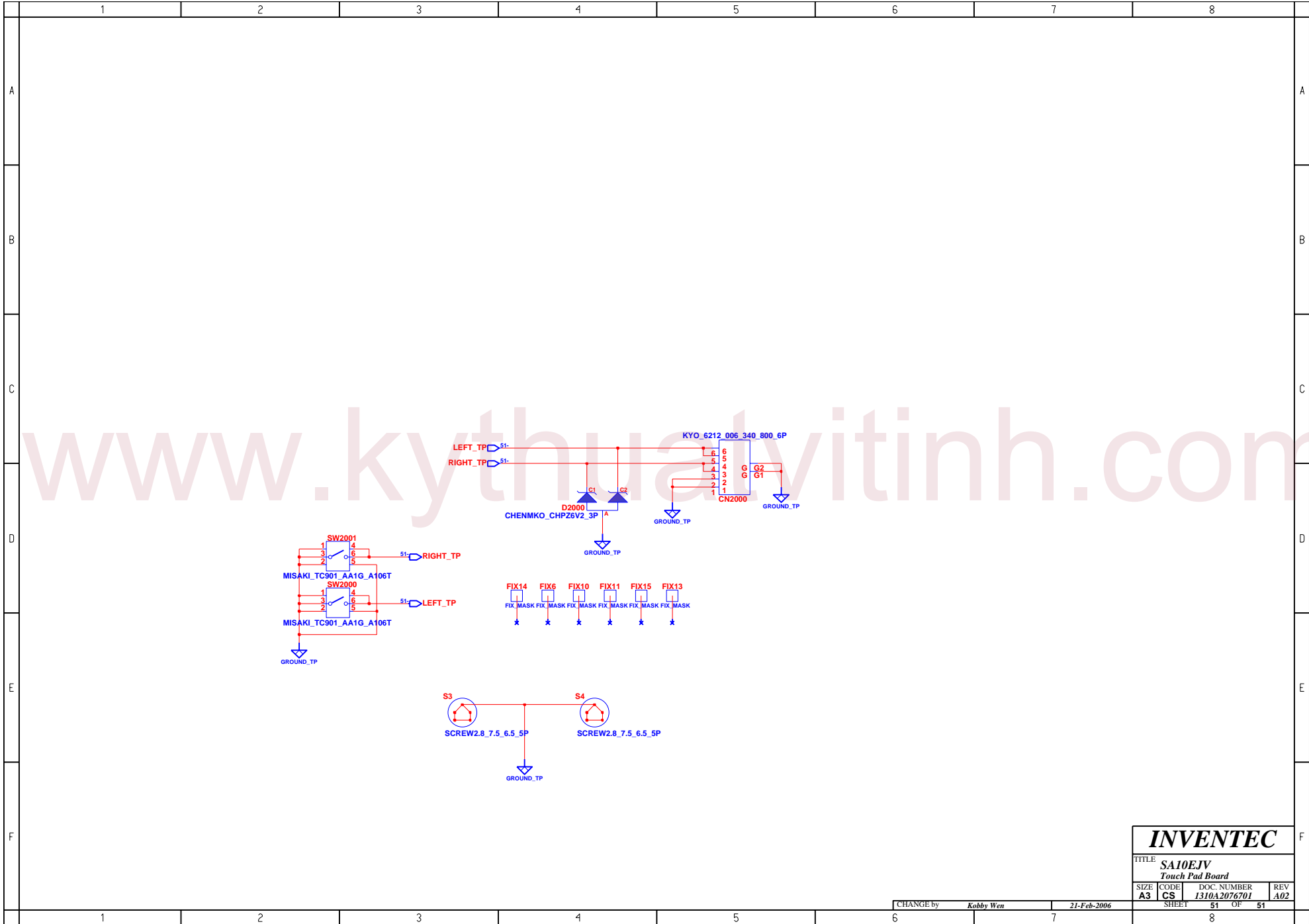

**INVENTEC**

TITLE **SA10EJV**  
Touch Pad Board

SIZE <b>A3</b>	CODE <b>CS</b>	DOC. NUMBER <b>1310A2076701</b>	REV <b>A02</b>
----------------	----------------	---------------------------------	----------------

CHANGE by *Kobby Wen* 21-Feb-2006

SHEET 51 OF 51